



COMMERCIAL WALK-IN COOLERS AND FREEZERS

LSA Models

Ideal for coolers above +34°F

- Low Silhouette, draw through, high velocity units
- Capacity from 4,500 to 39,000 Btu/hr./10°F TD

LSE, LSR and LST Models

Ideal for coolers and freezers from -20°F to +34°F

- Low Silhouette, draw through, high velocity units
- Capacity from 4,300 to 37,000 Btu/hr./10°F TD

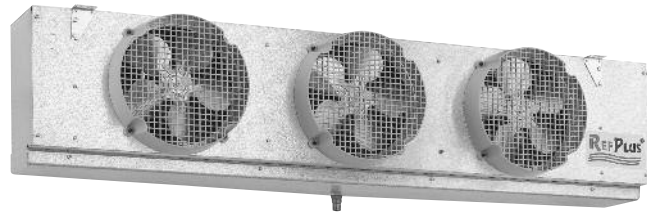

LPA Models

Ideal for coolers above +34°F

- Low Profile, blow through, medium velocity units
- Capacity from 6,000 to 42,000 Btu/hr./10°F TD

LPE, LPG & LPH Models

Ideal for coolers above +26°F

- Low Profile, blow through, medium velocity units
- Capacity from 5,700 to 40,000 Btu/hr./10°F TD



LAA Models

Ideal for coolers above +34°F

- Low Air, blow through, low velocity units
- Capacity from 6,000 to 46,000 Btu/hr./10°F TD

LAE, LAG & LAH Models

Ideal for coolers above +26°F

- Low Air, blow through, low velocity units
- Capacity from 5,700 to 44,000 Btu/hr./10°F TD



TABLE OF CONTENTS

| | |
|---------------------------------------|----|
| Nomenclature | 2 |
| Features & Options | 3 |
| Capacity Data (LSA, LSE, LSR, LST) | 4 |
| Dimensional Data (LSA, LSE, LSR, LST) | 5 |
| Capacity Data (LPA, LPE, LPG, LPH) | 6 |
| Dimensional Data (LPA, LPE, LPG, LPH) | 7 |
| Capacity Data (LAA, LAE, LAG, LAH) | 8 |
| Dimensional Data (LAA, LAE, LAG, LAH) | 9 |
| Piping Diagrams | 10 |
| Electrical Diagrams | 11 |
| Specifications | 12 |

UNIT COOLER NOMENCLATURE

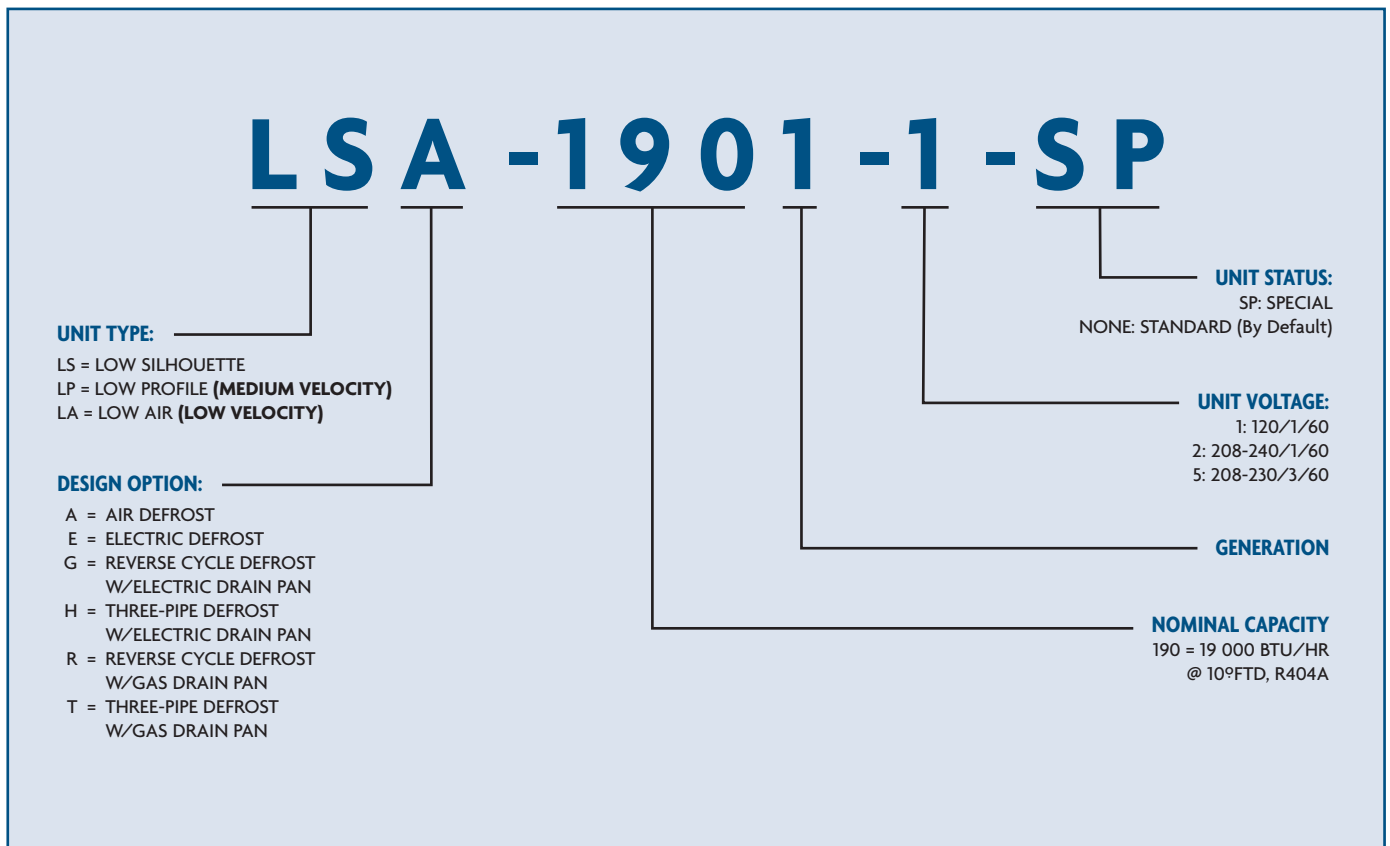

LS SERIES

STANDARD FEATURES

- Front & side access
- PSC motors
- Positive slope drain pan
- Central drain connection on the back of the unit
- Large $7/8$ " ID drain connection
- Ease of modifying, on the job site, to and from any defrost system
- Front-facing electrical board

OPTIONAL FEATURES

- EC motors
- Installed expansion valve
- Black epoxy-coated welded wire guard
- Mounting brackets kit to match mounting holes of preceding generation with the same casing length
- Hot gas defrost kit (LSR or LST models only)

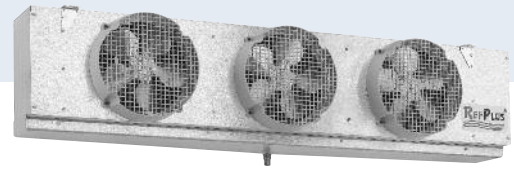

LP & LA SERIES

STANDARD FEATURES

- Low height to maximize storage space
- Shaded pole motors on small fan units
- PSC motors on large fan units
- Black epoxy-coated welded wire guard
- Triple drain pan to almost eliminate condensation under the unit
- Horizontal $3/4$ " FPT aluminum drain connection
- Hinged mounted external drain pan (also removable)
- Ease of modifying, on the job site, to and from any defrost system

OPTIONAL FEATURES

- EC motors (certain units only)
- Installed expansion valve

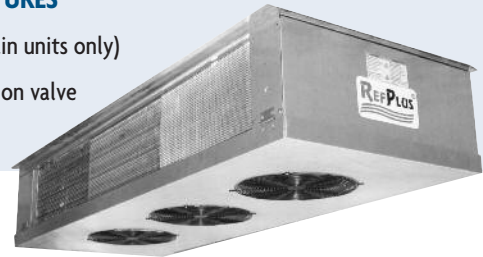

ECM MOTOR OPTION

RefPlus now offers the ECM motor option on several of its commercial walk-in coolers. Our new ECM motor option uses less wattage to achieve the same airflow as our standard motors. As a result, the ECM motor produces less heat in the system, which in turn means less work and wear for the compressor. This combination results in even greater energy savings.

- Eco-friendly electric motors
- Significant energy savings compared to standard motors
- Soft starts and slewed speeds eliminate stress transmitted to hardware

CAPACITY DATA (LSA, LSE, LSR, LST)

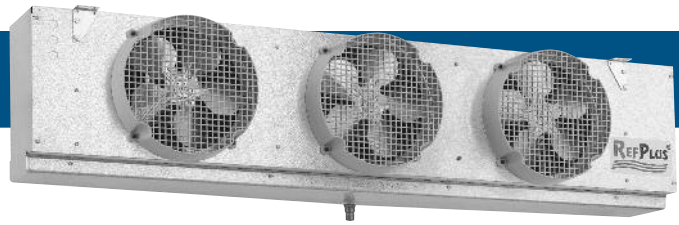

LSA - AIR DEFROST

FOR COOLERS ABOVE +34°F

| MODEL | CFM | CAPACITY | | | | ELECTRICAL 120/1/60 | | | | ELECTRICAL 240/1/60 OPTION | | | | R-404a, R-507 OPERATING CHARGE (LB) |
|------------|------|----------|---------|---------|---------|---------------------|-----|-----|------|----------------------------|-----|-----|-----|---|
| | | Btu/hr | | | | FAN MOTOR | | MCA | MOP | FAN MOTOR | | MCA | MOP | |
| | | 8° FTD | 10° FTD | 12° FTD | 15° FTD | QTY | FLA | | | QTY | FLA | | | |
| LSA 0451-1 | 1060 | 3600 | 4500 | 5400 | 6750 | 1 | 1.0 | 1.3 | 15.0 | 1 | 0.5 | 0.6 | 15 | 0.6 |
| LSA 0551-1 | 950 | 4400 | 5500 | 6600 | 8250 | 1 | 1.0 | 1.3 | 15.0 | 1 | 0.5 | 0.6 | 15 | 0.8 |
| LSA 0651-1 | 950 | 5200 | 6500 | 7800 | 9750 | 1 | 1.0 | 1.3 | 15.0 | 1 | 0.5 | 0.6 | 15 | 0.9 |
| LSA 0751-1 | 1900 | 6000 | 7500 | 9000 | 11250 | 2 | 2.0 | 2.3 | 15.0 | 2 | 1.0 | 1.1 | 15 | 0.9 |
| LSA 0921-1 | 1700 | 7360 | 9200 | 11040 | 13800 | 2 | 2.0 | 2.3 | 15.0 | 2 | 1.0 | 1.1 | 15 | 1.2 |
| LSA 1081-1 | 1700 | 8640 | 10800 | 12960 | 16200 | 2 | 2.0 | 2.3 | 15.0 | 2 | 1.0 | 1.1 | 15 | 1.4 |
| LSA 1301-1 | 1900 | 10400 | 13000 | 15600 | 19500 | 2 | 2.0 | 2.3 | 15.0 | 2 | 1.0 | 1.1 | 15 | 1.8 |
| LSA 1401-1 | 3200 | 11200 | 14000 | 16800 | 21000 | 3 | 3.0 | 3.3 | 15.0 | 3 | 1.5 | 1.6 | 15 | 1.6 |
| LSA 1601-1 | 2800 | 12800 | 16000 | 19200 | 24000 | 3 | 3.0 | 3.3 | 15.0 | 3 | 1.5 | 1.6 | 15 | 2.1 |
| LSA 1901-1 | 2800 | 15200 | 19000 | 22800 | 28500 | 3 | 3.0 | 3.3 | 15.0 | 3 | 1.5 | 1.6 | 15 | 2.6 |
| LSA 2301-1 | 3800 | 18400 | 23000 | 27600 | 34500 | 4 | 4.0 | 4.3 | 15.0 | 4 | 2.0 | 2.1 | 15 | 2.8 |
| LSA 2601-1 | 3830 | 20800 | 26000 | 31200 | 39000 | 4 | 4.0 | 4.3 | 15.0 | 4 | 2.0 | 2.1 | 15 | 3.5 |
| LSA 3201-1 | 4700 | 25600 | 32000 | 38400 | 48000 | 5 | 5.0 | 5.3 | 15.0 | 5 | 2.5 | 2.6 | 15 | 4.3 |
| LSA 3901-1 | 5600 | 31200 | 39000 | 46800 | 58500 | 6 | 6.0 | 6.3 | 15.0 | 6 | 3.0 | 3.1 | 15 | 5.2 |

For 4 fpi, multiply capacity by 0.8

See Wiring Diagram, Figure 1

LSE - ELECTRIC DEFROST

FOR COOLERS AND FREEZERS FROM -20°F TO +34°F

| MODEL | CFM | CAPACITY | | | | 240/1/60 | | DEFROST HEATERS | | | | | | | | | R-404a, R-507 OPERATING CHARGE (LB) |
|------------|------|------------------|-------|-------|-------|-----------|-----|-----------------|------|-----|----------|------|-----|----------|------|-----|---|
| | | BTU/hr @ 10°F TD | | | | FAN MOTOR | | 240/1/60 | | | 208/3/60 | | | 240/3/60 | | | |
| | | -30°F | -20°F | 0°F | +20°F | QTY | FLA | KW | FLA | MOP | KW | FLA | MOP | KW | FLA | MOP | |
| LSE 0431-2 | 1060 | 3560 | 3740 | 4020 | 4300 | 1 | 0.5 | 0.96 | 4.0 | 15 | 0.96 | 2.7 | 15 | 1.28 | 3.1 | 15 | 0.6 |
| LSE 0521-2 | 950 | 4310 | 4520 | 4860 | 5200 | 1 | 0.5 | 0.96 | 4.0 | 15 | 0.96 | 2.7 | 15 | 1.28 | 3.1 | 15 | 0.8 |
| LSE 0621-2 | 950 | 5140 | 5390 | 5795 | 6200 | 1 | 0.5 | 0.96 | 4.0 | 15 | 0.96 | 2.7 | 15 | 1.28 | 3.1 | 15 | 0.9 |
| LSE 0721-2 | 1900 | 5970 | 6260 | 6730 | 7200 | 2 | 1.0 | 1.50 | 6.3 | 15 | 1.50 | 4.2 | 15 | 2.00 | 4.8 | 15 | 0.9 |
| LSE 0881-2 | 1700 | 7290 | 7650 | 8225 | 8800 | 2 | 1.0 | 1.50 | 6.3 | 15 | 1.50 | 4.2 | 15 | 2.00 | 4.8 | 15 | 1.2 |
| LSE 1031-2 | 1700 | 8540 | 8960 | 9630 | 10300 | 2 | 1.0 | 1.50 | 6.3 | 15 | 1.50 | 4.2 | 15 | 2.00 | 4.8 | 15 | 1.4 |
| LSE 1241-2 | 1900 | 10270 | 10780 | 11590 | 12400 | 2 | 1.0 | 1.92 | 8.0 | 15 | 1.92 | 5.3 | 15 | 2.56 | 6.2 | 15 | 1.8 |
| LSE 1331-2 | 3200 | 11120 | 11670 | 12485 | 13300 | 3 | 1.5 | 2.88 | 12.0 | 15 | 2.88 | 8.0 | 15 | 3.84 | 9.2 | 15 | 1.6 |
| LSE 1521-2 | 2800 | 12600 | 13220 | 14210 | 15200 | 3 | 1.5 | 2.88 | 12.0 | 15 | 2.88 | 8.0 | 15 | 3.84 | 9.2 | 15 | 2.1 |
| LSE 1801-2 | 2800 | 14921 | 15650 | 16825 | 18000 | 3 | 1.5 | 2.88 | 12.0 | 15 | 2.88 | 8.0 | 15 | 3.84 | 9.2 | 15 | 2.6 |
| LSE 2201-2 | 3800 | 18230 | 19130 | 20565 | 22000 | 4 | 2.0 | 3.84 | 16.0 | 20 | 3.84 | 10.7 | 15 | 5.12 | 12.3 | 20 | 2.8 |
| LSE 2401-2 | 3830 | 19890 | 20870 | 22435 | 24000 | 4 | 2.0 | 3.84 | 16.0 | 20 | 3.84 | 10.7 | 15 | 5.12 | 12.3 | 20 | 3.5 |
| LSE 3001-2 | 4700 | 24860 | 26090 | 28045 | 30000 | 5 | 2.5 | 4.80 | 20.0 | 25 | 4.80 | 13.3 | 20 | 6.40 | 15.4 | 20 | 4.3 |
| LSE 3701-2 | 5600 | 30660 | 32170 | 34585 | 37000 | 6 | 3.0 | 5.76 | 24.0 | 30 | 5.76 | 16.0 | 20 | 7.68 | 18.5 | 25 | 5.2 |

For 4 fpi, multiply capacity by 0.8

See Wiring Diagram, Figure 3

LSR / LST - GAS DEFROST

FOR COOLERS AND FREEZERS FROM -20°F TO +34°F

| MODEL | CFM | CAPACITY | | | | ELECTRICAL 120/1/60 | | | | ELECTRICAL 240/1/60 OPTION | | | | R-404a, R-507 OPERATING CHARGE (LB) |
|-----------------|------|------------------|-------|-------|-------|---------------------|-----|-----|------|----------------------------|-----|-----|-----|---|
| | | BTU/hr @ 10°F TD | | | | FAN MOTOR | | MCA | MOP | FAN MOTOR | | MCA | MOP | |
| | | -30°F | -20°F | 0°F | +20°F | QTY | FLA | | | QTY | FLA | | | |
| LS(R)(T) 0431-1 | 1060 | 3560 | 3740 | 4020 | 4300 | 1 | 1.0 | 1.3 | 15.0 | 1 | 0.5 | 0.6 | 15 | 0.6 |
| LS(R)(T) 0521-1 | 950 | 4310 | 4520 | 4860 | 5200 | 1 | 1.0 | 1.3 | 15.0 | 1 | 0.5 | 0.6 | 15 | 0.8 |
| LS(R)(T) 0621-1 | 950 | 5140 | 5390 | 5795 | 6200 | 1 | 1.0 | 1.3 | 15.0 | 1 | 0.5 | 0.6 | 15 | 0.9 |
| LS(R)(T) 0721-1 | 1900 | 5970 | 6260 | 6730 | 7200 | 2 | 2.0 | 2.3 | 15.0 | 2 | 1.0 | 1.1 | 15 | 0.9 |
| LS(R)(T) 0881-1 | 1700 | 7290 | 7650 | 8225 | 8800 | 2 | 2.0 | 2.3 | 15.0 | 2 | 1.0 | 1.1 | 15 | 1.2 |
| LS(R)(T) 1031-1 | 1700 | 8540 | 8960 | 9630 | 10300 | 2 | 2.0 | 2.3 | 15.0 | 2 | 1.0 | 1.1 | 15 | 1.4 |
| LS(R)(T) 1241-1 | 1900 | 10270 | 10780 | 11590 | 12400 | 2 | 2.0 | 2.3 | 15.0 | 2 | 1.0 | 1.1 | 15 | 1.8 |
| LS(R)(T) 1331-1 | 3200 | 11120 | 11670 | 12485 | 13300 | 3 | 3.0 | 3.3 | 15.0 | 3 | 1.5 | 1.6 | 15 | 1.6 |
| LS(R)(T) 1521-1 | 2800 | 12600 | 13220 | 14210 | 15200 | 3 | 3.0 | 3.3 | 15.0 | 3 | 1.5 | 1.6 | 15 | 2.1 |
| LS(R)(T) 1801-1 | 2800 | 14921 | 15650 | 16825 | 18000 | 3 | 3.0 | 3.3 | 15.0 | 3 | 1.5 | 1.6 | 15 | 2.6 |
| LS(R)(T) 2201-1 | 3800 | 18230 | 19130 | 20565 | 22000 | 4 | 4.0 | 4.3 | 15.0 | 4 | 2.0 | 2.1 | 15 | 2.8 |
| LS(R)(T) 2401-1 | 3830 | 19890 | 20870 | 22435 | 24000 | 4 | 4.0 | 4.3 | 15.0 | 4 | 2.0 | 2.1 | 15 | 3.5 |
| LS(R)(T) 3001-1 | 4700 | 24860 | 26090 | 28045 | 30000 | 5 | 5.0 | 5.3 | 15.0 | 5 | 2.5 | 2.6 | 15 | 4.3 |
| LS(R)(T) 3701-1 | 5600 | 30660 | 32170 | 34585 | 37000 | 6 | 6.0 | 6.3 | 15.0 | 6 | 3.0 | 3.1 | 15 | 5.2 |

For 4 fpi, multiply capacity by 0.8

See Wiring Diagram, Figure 2

Use LSR model for reverse cycle defrost with gas drain pan (See piping diagram on page 10)
Use LST model for three-pipe cycle defrost with gas drain pan (See piping diagram on page 10)

NOTE :

- Operating charge based on 30% liquid and 70% vapor at 25°F suction
- Fan Motor heat is not included in rating, add for PSC motor (100W) 342 BTU/HR
- Fan Motor heat is not included in rating, add for EC motor (60W) 205 BTU/HR
- For 200-240/1/50 use suffix 2 and multiply capacity by 0.92
- For R134a refrigerant charge, multiply R-404a by 1.09
- Air throw for LS series is 25 to 35 ft.

LS SERIES

| MODEL | SHIPPING WEIGHT (lb) | MODEL | SHIPPING WEIGHT (lb) | MODEL | SHIPPING WEIGHT (lb) | UNIT DIMENSIONS (inches) | | | CONNECTION (inches) | | |
|----------|----------------------|----------|----------------------|---------------|----------------------|--------------------------|---------------------------------|----|---------------------|-------------------------------|-------------|
| | | | | | | W | A | B | LIQUID | SUCTION | LST HOT GAS |
| LSA 0451 | 26 | LSE 0431 | 27 | LS(R)(T) 0431 | 28 | 32 | 21 ¹ / ₄ | - | 1/2 | 5/8 | 1/2 |
| LSA 0551 | 29 | LSE 0521 | 30 | LS(R)(T) 0521 | 31 | 32 | 21 ¹ / ₄ | - | 1/2 | 5/8 | 1/2 |
| LSA 0651 | 30 | LSE 0621 | 31 | LS(R)(T) 0621 | 32 | 32 | 21 ¹ / ₄ | - | 1/2 | 5/8 | 1/2 |
| LSA 0751 | 38 | LSE 0721 | 40 | LS(R)(T) 0721 | 41 | 44 | 33 ¹ / ₄ | - | 1/2 | 5/8 | 1/2 |
| LSA 0921 | 42 | LSE 0881 | 44 | LS(R)(T) 0881 | 45 | 44 | 33 ¹ / ₄ | - | 1/2 | 7/8 | 1/2 |
| LSA 1081 | 42 | LSE 1031 | 44 | LS(R)(T) 1031 | 45 | 44 | 33 ¹ / ₄ | - | 1/2 | 7/8 | 1/2 |
| LSA 1301 | 47 | LSE 1241 | 49 | LS(R)(T) 1241 | 51 | 52 | 41 ¹ / ₄ | - | 1/2 | 7/8 | 1/2 |
| LSA 1401 | 58 | LSE 1331 | 60 | LS(R)(T) 1331 | 63 | 72 | 61 ¹ / ₄ | - | 1/2 | 7/8 | 1/2 |
| LSA 1601 | 67 | LSE 1521 | 70 | LS(R)(T) 1521 | 72 | 72 | 61 ¹ / ₄ | - | 1/2 | 7/8 | 1/2 |
| LSA 1901 | 68 | LSE 1801 | 71 | LS(R)(T) 1801 | 73 | 72 | 61 ¹ / ₄ | - | 1/2 | 7/8 | 1/2 |
| LSA 2301 | 88 | LSE 2201 | 92 | LS(R)(T) 2201 | 95 | 92 | 81 ¹ / ₄ | 40 | 1/2 | 7/8 | 5/8 |
| LSA 2601 | 89 | LSE 2401 | 93 | LS(R)(T) 2401 | 96 | 92 | 81 ¹ / ₄ | 40 | 1/2 | 1 ¹ / ₈ | 5/8 |
| LSA 3201 | 108 | LSE 3001 | 112 | LS(R)(T) 3001 | 116 | 112 | 101 ¹ / ₄ | 40 | 1/2 | 1 ¹ / ₈ | 5/8 |
| LSA 3901 | 127 | LSE 3701 | 132 | LS(R)(T) 3701 | 136 | 132 | 121 ¹ / ₄ | 60 | 1/2 | 1 ¹ / ₈ | 5/8 |

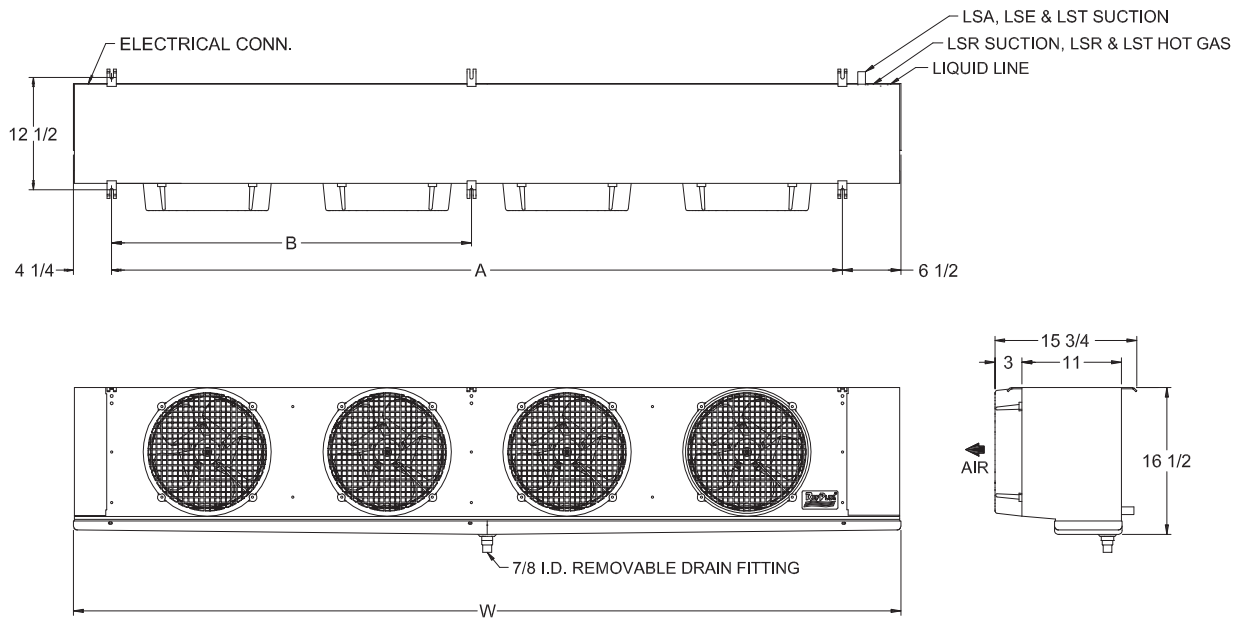

CAPACITY DATA (LPA, LPE, LPG, LPH)



LPA - AIR DEFROST

FOR COOLERS ABOVE +34°F

| MODEL | CFM | CAPACITY | | | | ELECTRICAL 120/1/60 | | | | ELECTRICAL 240/1/60 OPTION | | | | R-404a, R-507 OPERATING CHARGE (LB) |
|------------|------|----------|---------|---------|---------|---------------------|-----|-----|-----|----------------------------|-----|-----|-----|---|
| | | BTU/hr | | | | FAN MOTOR | | MCA | MOP | FAN MOTOR | | MCA | MOP | |
| | | 8° FTD | 10° FTD | 12° FTD | 15° FTD | QTY | FLA | | | QTY | FLA | | | |
| LPA 0601-1 | 800 | 4800 | 6000 | 7200 | 9000 | 2 | 1.5 | 1.7 | 15 | 2 | 0.7 | 0.8 | 15 | 0.9 |
| LPA 0701-1 | 880 | 5600 | 7000 | 8400 | 10500 | 2 | 1.5 | 1.7 | 15 | 2 | 0.7 | 0.8 | 15 | 1.1 |
| LPA 0801-1 | 850 | 6400 | 8000 | 9600 | 12000 | 2 | 1.5 | 1.7 | 15 | 2 | 0.7 | 0.8 | 15 | 1.6 |
| LPA 1001-1 | 1350 | 8000 | 10000 | 12000 | 15000 | 3 | 2.2 | 2.4 | 15 | 3 | 1.1 | 1.2 | 15 | 1.6 |
| LPA 1201-1 | 1250 | 9600 | 12000 | 14400 | 18000 | 3 | 2.2 | 2.4 | 15 | 3 | 1.1 | 1.2 | 15 | 2.3 |
| LPA 1601-1 | 1660 | 12800 | 16000 | 19200 | 24000 | 4 | 3.0 | 3.2 | 15 | 4 | 1.5 | 1.5 | 15 | 3.0 |
| LPA 2001-1 | 2090 | 16000 | 20000 | 24000 | 30000 | 5 | 3.7 | 3.9 | 15 | 5 | 1.8 | 1.9 | 15 | 3.8 |
| LPA 2101-1 | 3200 | 16800 | 21000 | 25200 | 31500 | 3 | 3.0 | 3.3 | 15 | 3 | 1.5 | 1.6 | 15 | 3.6 |
| LPA 2401-1 | 2500 | 19200 | 24000 | 28800 | 36000 | 6 | 4.5 | 4.6 | 15 | 6 | 2.2 | 2.3 | 15 | 4.5 |
| LPA 2801-1 | 4200 | 22400 | 28000 | 33600 | 42000 | 4 | 4.0 | 4.3 | 15 | 4 | 2.0 | 2.1 | 15 | 4.8 |
| LPA 3501-1 | 5400 | 28000 | 35000 | 42000 | 52500 | 5 | 5.0 | 5.3 | 15 | 5 | 2.5 | 2.6 | 15 | 5.9 |
| LPA 4201-1 | 6500 | 33600 | 42000 | 50400 | 63000 | 6 | 6.0 | 6.3 | 15 | 6 | 3.0 | 3.1 | 15 | 7.1 |

For 4 fpi, multiply capacity by 0.8

See Wiring Diagram, Figure 1

LPE - ELECTRIC DEFROST

FOR COOLERS FROM +26°F TO +34°F

| MODEL | CFM | CAPACITY | | | | 240/1/60 | | DEFROST HEATERS | | | | | | | | | R-404a, R-507 OPERATING CHARGE (LB) |
|------------|------|----------|---------|---------|---------|-----------|-----|-----------------|------|-----|----------|------|-----|----------|------|-----|---|
| | | BTU/hr | | | | FAN MOTOR | | 240/1/60 | | | 208/3/60 | | | 240/3/60 | | | |
| | | 8° FTD | 10° FTD | 12° FTD | 15° FTD | QTY | FLA | KW | FLA | MOP | KW | FLA | MOP | KW | FLA | MOP | |
| LPE 0571-2 | 800 | 4560 | 5700 | 6840 | 8550 | 2 | 0.7 | 1.50 | 6.3 | 15 | 1.50 | 4.2 | 15 | 2.00 | 4.8 | 15 | 0.9 |
| LPE 0671-2 | 880 | 5360 | 6700 | 8040 | 10050 | 2 | 0.7 | 1.92 | 8.0 | 15 | 1.92 | 5.3 | 15 | 2.56 | 6.2 | 15 | 1.1 |
| LPE 0761-2 | 850 | 6080 | 7600 | 9120 | 11400 | 2 | 0.7 | 1.92 | 8.0 | 15 | 1.92 | 5.3 | 15 | 2.56 | 6.2 | 15 | 1.6 |
| LPE 0951-2 | 1350 | 7600 | 9500 | 11400 | 14250 | 3 | 1.1 | 2.88 | 12.0 | 15 | 2.88 | 8.0 | 15 | 3.84 | 9.2 | 15 | 1.6 |
| LPE 1151-2 | 1250 | 9200 | 11500 | 13800 | 17250 | 3 | 1.1 | 2.88 | 12.0 | 15 | 2.88 | 8.0 | 15 | 3.84 | 9.2 | 15 | 2.3 |
| LPE 1521-2 | 1660 | 12160 | 15200 | 18240 | 22800 | 4 | 1.5 | 3.84 | 16.0 | 20 | 3.84 | 10.7 | 15 | 5.12 | 12.3 | 20 | 3 |
| LPE 1901-2 | 2090 | 15200 | 19000 | 22800 | 28500 | 5 | 1.8 | 4.80 | 20.0 | 25 | 4.80 | 13.3 | 20 | 6.40 | 15.4 | 20 | 3.8 |
| LPE 2001-2 | 3200 | 16000 | 20000 | 24000 | 30000 | 3 | 1.5 | 2.88 | 12.0 | 15 | 2.88 | 8.0 | 15 | 3.84 | 9.2 | 15 | 3.6 |
| LPE 2301-2 | 2500 | 18400 | 23000 | 27600 | 34500 | 6 | 2.2 | 5.76 | 24.0 | 30 | 5.76 | 16.0 | 20 | 7.68 | 18.5 | 25 | 4.5 |
| LPE 2701-2 | 4200 | 21600 | 27000 | 32400 | 40500 | 4 | 2.0 | 3.84 | 16.0 | 20 | 3.84 | 10.7 | 15 | 5.12 | 12.3 | 20 | 4.8 |
| LPE 3341-2 | 5400 | 26720 | 33400 | 40080 | 50100 | 5 | 2.5 | 4.80 | 20.0 | 25 | 4.80 | 13.3 | 20 | 6.40 | 15.4 | 20 | 5.9 |
| LPE 4001-2 | 6500 | 32000 | 40000 | 48000 | 60000 | 6 | 3.0 | 5.76 | 24.0 | 30 | 5.76 | 16.0 | 20 | 7.68 | 18.5 | 25 | 7.1 |

For 4 fpi, multiply capacity by 0.8

See Wiring Diagram, Figure 3

LPG/LPH - GAS DEFROST

FOR COOLERS FROM +26°F TO +34°F

| MODEL | CFM | CAPACITY | | | | 120/1/60 | | 240/1/60 | | DEFROST HEATERS | | | | | | R-404a, R-507 OPERATING CHARGE (LB) |
|-----------------|------|----------|---------|---------|---------|-----------|-----|-----------|-----|-----------------|------|-----|----------|-----|-----|---|
| | | BTU/hr | | | | FAN MOTOR | | FAN MOTOR | | 120/1/60 | | | 240/1/60 | | | |
| | | 8° FTD | 10° FTD | 12° FTD | 15° FTD | QTY | FLA | QTY | FLA | KW | FLA | MOP | KW | FLA | MOP | |
| LP(G)(H) 0571-1 | 800 | 4560 | 5700 | 6840 | 8550 | 2 | 1.5 | 2 | 0.7 | 0.50 | 4.2 | 15 | 0.50 | 2.1 | 15 | 0.9 |
| LP(G)(H) 0671-1 | 880 | 5360 | 6700 | 8040 | 10050 | 2 | 1.5 | 2 | 0.7 | 0.64 | 5.3 | 15 | 0.64 | 2.7 | 15 | 1.1 |
| LP(G)(H) 0761-1 | 850 | 6080 | 7600 | 9120 | 11400 | 2 | 1.5 | 2 | 0.7 | 0.64 | 5.3 | 15 | 0.64 | 2.7 | 15 | 1.6 |
| LP(G)(H) 0951-1 | 1350 | 7600 | 9500 | 11400 | 14250 | 3 | 2.2 | 3 | 1.1 | 0.96 | 8.0 | 15 | 0.96 | 4.0 | 15 | 1.6 |
| LP(G)(H) 1151-1 | 1250 | 9200 | 11500 | 13800 | 17250 | 3 | 2.2 | 3 | 1.1 | 0.96 | 8.0 | 15 | 0.96 | 4.0 | 15 | 2.3 |
| LP(G)(H) 1521-1 | 1660 | 12160 | 15200 | 18240 | 22800 | 4 | 3.0 | 4 | 1.5 | 1.28 | 10.7 | 15 | 1.28 | 5.3 | 15 | 3 |
| LP(G)(H) 1901-1 | 2090 | 15200 | 19000 | 22800 | 28500 | 5 | 3.7 | 5 | 1.8 | 1.60 | 13.3 | 20 | 1.60 | 6.7 | 15 | 3.8 |
| LP(G)(H) 2001-1 | 3200 | 16000 | 20000 | 24000 | 30000 | 3 | 3.0 | 3 | 1.5 | 0.96 | 8.0 | 15 | 0.96 | 4.0 | 15 | 3.6 |
| LP(G)(H) 2301-1 | 2500 | 18400 | 23000 | 27600 | 34500 | 6 | 4.5 | 6 | 2.2 | 1.92 | 16.0 | 20 | 1.92 | 8.0 | 15 | 4.5 |
| LP(G)(H) 2701-1 | 4200 | 21600 | 27000 | 32400 | 40500 | 4 | 4.0 | 4 | 2.0 | 1.28 | 10.7 | 15 | 1.28 | 5.3 | 15 | 4.8 |
| LP(G)(H) 3341-1 | 5400 | 26720 | 33400 | 40080 | 50100 | 5 | 5.0 | 5 | 2.5 | 1.60 | 13.3 | 20 | 1.60 | 6.7 | 15 | 5.9 |
| LP(G)(H) 4001-1 | 6500 | 32000 | 40000 | 48000 | 60000 | 6 | 6.0 | 6 | 3.0 | 1.92 | 16.0 | 20 | 1.92 | 8.0 | 15 | 7.1 |

For 4 fpi, multiply capacity by 0.8

See Wiring Diagram, Figure 4

Use LPG model for reverse cycle defrost with electric drain pan (See piping diagram on page 10)

Use LPH model for three-pipe cycle defrost with electric drain pan (See piping diagram on page 10)

NOTE :

- Operating charge based on 30% liquid and 70% vapor at 25°F suction
- Fan Motor heat is not included in rating
Unit 0601 to 2001 and 2401, add for Shaded Pole motor (58W) 198 BTU/HR
Unit 2101 and 2801 to 4201, add for PSC motor (100W) 342 BTU/HR
Unit 2101 and 2801 to 4201, add for EC motor (60W) 205 BTU/HR
- For 200-240/1/50 use suffix 2 and multiply capacity by 0.92
- For R134a refrigerant charge, multiply R-404a by 1.09
- Air throw for LP series is 12 to 18 ft.

LP SERIES

| MODEL | SHIPPING WEIGHT (lb) | MODEL | SHIPPING WEIGHT (lb) | MODEL | SHIPPING WEIGHT (lb) | UNIT DIMENSIONS (inches) | | | | CONNECTION (inches) | | |
|----------|----------------------|----------|----------------------|---------------|----------------------|--------------------------|--------|-----|----|---------------------|---------|-------------|
| | | | | | | W | H | A | B | LIQUID | SUCTION | LPH HOT GAS |
| LPA 0601 | 95 | LPE 0571 | 105 | LP(G)(H) 0571 | 96 | 44 1/2 | 7 5/8 | 33 | - | 1/2 | 5/8 | 1/2 |
| LPA 0701 | 105 | LPE 0671 | 118 | LP(G)(H) 0671 | 107 | 52 1/2 | 7 5/8 | 41 | - | 1/2 | 5/8 | 1/2 |
| LPA 0801 | 110 | LPE 0761 | 123 | LP(G)(H) 0761 | 112 | 52 1/2 | 7 5/8 | 41 | - | 1/2 | 5/8 | 1/2 |
| LPA 1001 | 145 | LPE 0951 | 161 | LP(G)(H) 0951 | 149 | 72 1/2 | 7 7/8 | 61 | - | 1/2 | 5/8 | 1/2 |
| LPA 1201 | 152 | LPE 1151 | 168 | LP(G)(H) 1151 | 156 | 72 1/2 | 7 7/8 | 61 | - | 1/2 | 7/8 | 1/2 |
| LPA 1601 | 195 | LPE 1521 | 221 | LP(G)(H) 1521 | 200 | 92 1/2 | 7 7/8 | 81 | 40 | 1/2 | 7/8 | 1/2 |
| LPA 2001 | 240 | LPE 1901 | 273 | LP(G)(H) 1901 | 247 | 112 1/2 | 8 1/8 | 101 | 40 | 1/2 | 7/8 | 1/2 |
| LPA 2101 | 168 | LPE 2001 | 184 | LP(G)(H) 2001 | 172 | 72 1/2 | 12 7/8 | 61 | - | 1/2 | 7/8 | 1/2 |
| LPA 2401 | 282 | LPE 2301 | 322 | LP(G)(H) 2301 | 290 | 132 1/2 | 8 1/8 | 121 | 60 | 1/2 | 7/8 | 1/2 |
| LPA 2801 | 216 | LPE 2701 | 242 | LP(G)(H) 2701 | 221 | 92 1/2 | 12 7/8 | 81 | 40 | 1/2 | 7/8 | 1/2 |
| LPA 3501 | 266 | LPE 3341 | 299 | LP(G)(H) 3341 | 273 | 112 1/2 | 13 1/8 | 101 | 40 | 1/2 | 1 1/8 | 5/8 |
| LPA 4201 | 315 | LPE 4001 | 355 | LP(G)(H) 4001 | 323 | 132 1/2 | 13 1/8 | 121 | 60 | 1/2 | 1 1/8 | 5/8 |

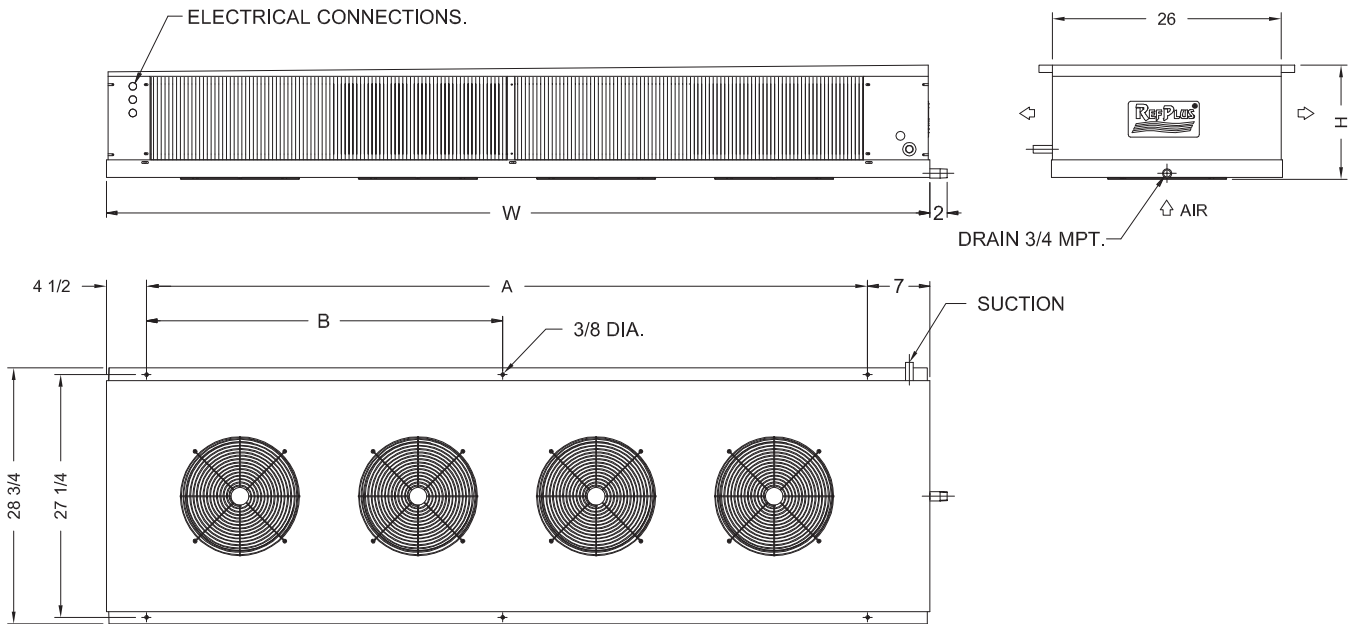

CAPACITY DATA (LAA, LAE, LAG, LAH)



LAA - AIR DEFROST

FOR COOLERS ABOVE +34°F

| MODEL | CFM | CAPACITY BTU/hr | | | | ELECTRICAL 120/1/60 | | | | ELECTRICAL 240/1/60 OPTION | | | | R-404a, R-507 OPERATING CHARGE (LB) |
|------------|------|--------------------|---------|---------|---------|---------------------|-----|-----|-----|----------------------------|-----|-----|-----|---|
| | | 8° FTD | 10° FTD | 12° FTD | 15° FTD | FAN MOTOR | | MCA | MOP | FAN MOTOR | | MCA | MOP | |
| | | | | | | QTY | FLA | | | QTY | FLA | | | |
| LAA 0601-1 | 1040 | 4800 | 6000 | 7200 | 9000 | 2 | 1.5 | 1.7 | 15 | 2 | 0.7 | 0.8 | 15 | 1.1 |
| LAA 0751-1 | 1000 | 6000 | 7500 | 9000 | 11250 | 2 | 1.5 | 1.7 | 15 | 2 | 0.7 | 0.8 | 15 | 1.8 |
| LAA 0951-1 | 980 | 7600 | 9500 | 11400 | 14250 | 2 | 1.5 | 1.7 | 15 | 2 | 0.7 | 0.8 | 15 | 2.5 |
| LAA 1201-1 | 1620 | 9600 | 12000 | 14400 | 18000 | 3 | 2.2 | 2.4 | 15 | 3 | 1.1 | 1.2 | 15 | 2.6 |
| LAA 1501-1 | 1560 | 12000 | 15000 | 18000 | 22500 | 3 | 2.2 | 2.4 | 15 | 3 | 1.1 | 1.2 | 15 | 3.6 |
| LAA 1801-1 | 1920 | 14400 | 18000 | 21600 | 27000 | 4 | 3.0 | 3.2 | 15 | 4 | 1.5 | 1.5 | 15 | 4.8 |
| LAA 2401-1 | 2510 | 19200 | 24000 | 28800 | 36000 | 5 | 3.7 | 3.9 | 15 | 5 | 1.8 | 1.9 | 15 | 5.9 |
| LAA 2801-1 | 2880 | 22400 | 28000 | 33600 | 42000 | 6 | 4.5 | 4.6 | 15 | 6 | 2.2 | 2.3 | 15 | 7.1 |
| LAA 3001-1 | 3810 | 24000 | 30000 | 36000 | 45000 | 3 | 3.0 | 3.3 | 15 | 3 | 1.5 | 1.6 | 15 | 5.9 |
| LAA 3601-1 | 4930 | 28800 | 36000 | 43200 | 54000 | 4 | 4.0 | 4.3 | 15 | 4 | 2.0 | 2.1 | 15 | 7.1 |
| LAA 4201-1 | 6162 | 33600 | 42000 | 50400 | 63000 | 5 | 5.0 | 5.3 | 15 | 5 | 2.5 | 2.6 | 15 | 9.2 |
| LAA 4601-1 | 7400 | 36800 | 46000 | 55200 | 69000 | 6 | 6.0 | 6.3 | 15 | 6 | 3.0 | 3.1 | 15 | 11.0 |

For 4 fpi, multiply capacity by 0.8

See Wiring Diagram, Figure 1

LAE - ELECTRIC DEFROST

FOR COOLERS FROM +26°F TO +34°F

| MODEL | CFM | CAPACITY BTU/hr | | | | 240/1/60 | | DEFROST HEATERS | | | | | | | | | R-404a, R-507 OPERATING CHARGE (LB) |
|------------|------|--------------------|---------|---------|---------|-----------|-----|-----------------|------|-----|----------|------|-----|----------|------|-----|---|
| | | 8° FTD | 10° FTD | 12° FTD | 15° FTD | FAN MOTOR | | 240/1/60 | | | 208/3/60 | | | 240/3/60 | | | |
| | | | | | | QTY | FLA | KW | FLA | MOP | KW | FLA | MOP | KW | FLA | MOP | |
| LAE 0571-2 | 1040 | 4560 | 5700 | 6840 | 8550 | 2 | 0.7 | 1.92 | 8.0 | 15 | 1.92 | 5.3 | 15 | 2.56 | 6.2 | 15 | 1.1 |
| LAE 0721-2 | 1000 | 5760 | 7200 | 8640 | 10800 | 2 | 0.7 | 1.92 | 8.0 | 15 | 1.92 | 5.3 | 15 | 2.56 | 6.2 | 15 | 1.8 |
| LAE 0901-2 | 980 | 7200 | 9000 | 10800 | 13500 | 2 | 0.7 | 1.92 | 8.0 | 15 | 1.92 | 5.3 | 15 | 2.56 | 6.2 | 15 | 2.5 |
| LAE 1141-2 | 1620 | 9120 | 11400 | 13680 | 17100 | 3 | 1.1 | 2.88 | 12.0 | 15 | 2.88 | 8.0 | 15 | 3.84 | 9.2 | 15 | 2.6 |
| LAE 1431-2 | 1560 | 11440 | 14300 | 17160 | 21450 | 3 | 1.1 | 2.88 | 12.0 | 15 | 2.88 | 8.0 | 15 | 3.84 | 9.2 | 15 | 3.6 |
| LAE 1701-2 | 1920 | 13600 | 17000 | 20400 | 25500 | 4 | 1.5 | 3.84 | 16.0 | 20 | 3.84 | 10.7 | 15 | 5.12 | 12.3 | 20 | 4.8 |
| LAE 2301-2 | 2510 | 18400 | 23000 | 27600 | 34500 | 5 | 1.8 | 4.80 | 20.0 | 25 | 4.80 | 13.3 | 20 | 6.40 | 15.4 | 20 | 5.9 |
| LAE 2701-2 | 2880 | 21600 | 27000 | 32400 | 40500 | 6 | 2.2 | 5.76 | 24.0 | 30 | 5.76 | 16.0 | 20 | 7.68 | 18.5 | 25 | 7.1 |
| LAE 2861-2 | 3810 | 22880 | 28600 | 34320 | 42900 | 3 | 1.5 | 4.80 | 20.0 | 25 | 4.80 | 13.3 | 20 | 6.40 | 15.4 | 20 | 5.9 |
| LAE 3431-2 | 4930 | 27440 | 34300 | 41160 | 51450 | 4 | 2.0 | 5.76 | 24.0 | 30 | 5.76 | 16.0 | 20 | 7.68 | 18.5 | 25 | 7.1 |
| LAE 4001-2 | 6162 | 32000 | 40000 | 48000 | 60000 | 5 | 2.5 | 4.80 | 20.0 | 25 | 4.80 | 13.3 | 20 | 6.40 | 15.4 | 20 | 9.2 |
| LAE 4381-2 | 7400 | 35040 | 43800 | 52560 | 65700 | 6 | 3.0 | 5.76 | 24.0 | 30 | 5.76 | 16.0 | 20 | 7.68 | 18.5 | 25 | 11.0 |

For 4 fpi, multiply capacity by 0.8

See Wiring Diagram, Figure 3

LAG/LAH - GAS DEFROST

FOR COOLERS FROM +26°F TO +34°F

| MODEL | CFM | CAPACITY BTU/hr | | | | 120/1/60 | | 240/1/60 | | DEFROST HEATERS | | | | | | R-404a, R-507 OPERATING CHARGE (LB) |
|-----------------|------|--------------------|---------|---------|---------|-----------|-----|-----------|-----|-----------------|------|-----|----------|-----|-----|---|
| | | 8° FTD | 10° FTD | 12° FTD | 15° FTD | FAN MOTOR | | FAN MOTOR | | 120/1/60 | | | 240/1/60 | | | |
| | | | | | | QTY | FLA | QTY | FLA | KW | FLA | MOP | KW | FLA | MOP | |
| LA(G)(H) 0601-1 | 1040 | 4560 | 5700 | 6840 | 8550 | 2 | 1.5 | 2 | 0.7 | 0.64 | 5.3 | 15 | 0.64 | 2.7 | 15 | 1.1 |
| LA(G)(H) 0751-1 | 1000 | 5760 | 7200 | 8640 | 10800 | 2 | 1.5 | 2 | 0.7 | 0.64 | 5.3 | 15 | 0.64 | 2.7 | 15 | 1.8 |
| LA(G)(H) 0951-1 | 980 | 7200 | 9000 | 10800 | 13500 | 2 | 1.5 | 2 | 0.7 | 0.64 | 5.3 | 15 | 0.64 | 2.7 | 15 | 2.5 |
| LA(G)(H) 1201-1 | 1620 | 9120 | 11400 | 13680 | 17100 | 3 | 2.2 | 3 | 1.1 | 0.96 | 8.0 | 15 | 0.96 | 4.0 | 15 | 2.6 |
| LA(G)(H) 1501-1 | 1560 | 11440 | 14300 | 17160 | 21450 | 3 | 2.2 | 3 | 1.1 | 0.96 | 8.0 | 15 | 0.96 | 4.0 | 15 | 3.6 |
| LA(G)(H) 1801-1 | 1920 | 13600 | 17000 | 20400 | 25500 | 4 | 3.0 | 4 | 1.5 | 1.28 | 10.7 | 15 | 1.28 | 5.3 | 15 | 4.8 |
| LA(G)(H) 2401-1 | 2510 | 18400 | 23000 | 27600 | 34500 | 5 | 3.7 | 5 | 1.8 | 1.60 | 13.3 | 20 | 1.60 | 6.7 | 15 | 5.9 |
| LA(G)(H) 2801-1 | 2880 | 21600 | 27000 | 32400 | 40500 | 6 | 4.4 | 6 | 2.2 | 1.92 | 16.0 | 20 | 1.92 | 8.0 | 15 | 7.1 |
| LA(G)(H) 3001-1 | 3810 | 22880 | 28600 | 34320 | 42900 | 3 | 3.0 | 3 | 1.5 | 1.60 | 13.3 | 20 | 1.60 | 6.7 | 15 | 5.9 |
| LA(G)(H) 3601-1 | 4930 | 27464 | 34330 | 41196 | 51495 | 4 | 4.0 | 4 | 2.0 | 1.92 | 16.0 | 20 | 1.92 | 8.0 | 15 | 7.1 |
| LA(G)(H) 4201-1 | 6162 | 32000 | 40000 | 48000 | 60000 | 5 | 5.0 | 5 | 2.5 | 1.60 | 13.3 | 20 | 1.60 | 6.7 | 15 | 9.2 |
| LA(G)(H) 4601-1 | 7400 | 35040 | 43800 | 52560 | 65700 | 6 | 6.0 | 6 | 3.0 | 1.92 | 16.0 | 20 | 1.92 | 8.0 | 15 | 11.0 |

For 4 fpi, multiply capacity by 0.8

See Wiring Diagram, Figure 4

Use LAG model for reverse cycle defrost with electric drain pan (See piping diagram on page 10)

Use LAH model for three-pipe cycle defrost with electric drain pan (See piping diagram on page 10)

NOTE :

- Operating charge based on 30% liquid and 70% vapor at 25°F suction
- Fan Motor heat is not included in rating
Unit 0601 to 2801, add for Shaded Pole motor (58W) 198 BTU/hr
Unit 3001 to 4601, add for PSC motor (100W) 341 BTU/hr
Unit 3001 to 4601, add for EC motor (60W) 2051 BTU/hr
- For 200-240/1/50 use suffix 2 and multiply capacity by 0.92
- For R134a refrigerant charge, multiply R-404a by 1.09
- Air throw for LA series is 10 to 15 ft.

LA SERIES

| MODEL | SHIPPING WEIGHT (lb) | MODEL | SHIPPING WEIGHT (lb) | MODEL | SHIPPING WEIGHT (lb) | UNIT DIMENSIONS (inches) | | | | CONNECTION (inches) | | |
|----------|----------------------|----------|----------------------|---------------|----------------------|--------------------------|--------|-----|----|---------------------|---------|-------------|
| | | | | | | W | H | A | B | LIQUID | SUCTION | LAH HOT GAS |
| LAA 0601 | 96 | LAE 0571 | 107 | LA(G)(H) 0571 | 99 | 44 1/2 | 10 1/8 | 33 | - | 1/2 | 5/8 | 1/2 |
| LAA 0751 | 113 | LAE 0721 | 126 | LA(G)(H) 0721 | 116 | 52 1/2 | 10 1/8 | 41 | - | 1/2 | 5/8 | 1/2 |
| LAA 0951 | 120 | LAE 0901 | 133 | LA(G)(H) 0901 | 123 | 52 1/2 | 10 1/8 | 41 | - | 1/2 | 5/8 | 1/2 |
| LAA 1201 | 158 | LAE 1141 | 174 | LA(G)(H) 1141 | 165 | 72 1/2 | 10 3/8 | 61 | - | 1/2 | 7/8 | 1/2 |
| LAA 1501 | 168 | LAE 1431 | 184 | LA(G)(H) 1431 | 173 | 72 1/2 | 10 3/8 | 61 | - | 1/2 | 7/8 | 1/2 |
| LAA 1801 | 215 | LAE 1701 | 241 | LA(G)(H) 1701 | 222 | 92 1/2 | 10 3/8 | 81 | 40 | 1/2 | 7/8 | 1/2 |
| LAA 2401 | 265 | LAE 2301 | 298 | LA(G)(H) 2301 | 277 | 112 1/2 | 10 3/8 | 101 | 40 | 1/2 | 7/8 | 1/2 |
| LAA 2801 | 310 | LAE 2701 | 350 | LA(G)(H) 2701 | 335 | 132 1/2 | 10 3/8 | 121 | 60 | 1/2 | 7/8 | 1/2 |
| LAA 3001 | 255 | LAE 2861 | 288 | LA(G)(H) 2861 | 268 | 112 1/2 | 13 1/8 | 101 | 40 | 1/2 | 1 1/8 | 1/2 |
| LAA 3601 | 302 | LAE 3431 | 342 | LA(G)(H) 3431 | 327 | 132 1/2 | 13 1/8 | 121 | 60 | 1/2 | 1 1/8 | 1/2 |
| LAA 4201 | 302 | LAE 4001 | 335 | LA(G)(H) 4001 | 315 | 112 1/2 | 18 1/8 | 101 | 40 | 1/2 | 1 1/8 | 5/8 |
| LAA 4601 | 355 | LAE 4381 | 395 | LA(G)(H) 4381 | 380 | 132 1/2 | 18 1/8 | 121 | 60 | 1/2 | 1 1/8 | 5/8 |

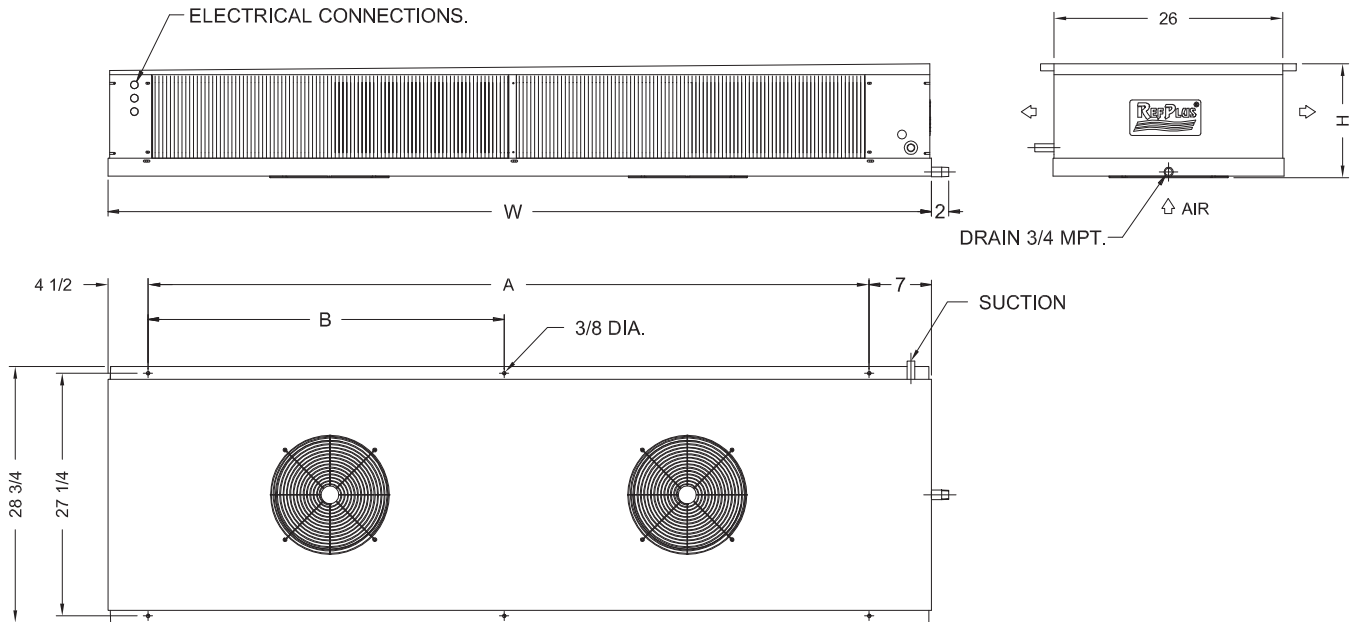

PIPING DIAGRAMS

LSR/LST STANDARD PIPING DIAGRAMS

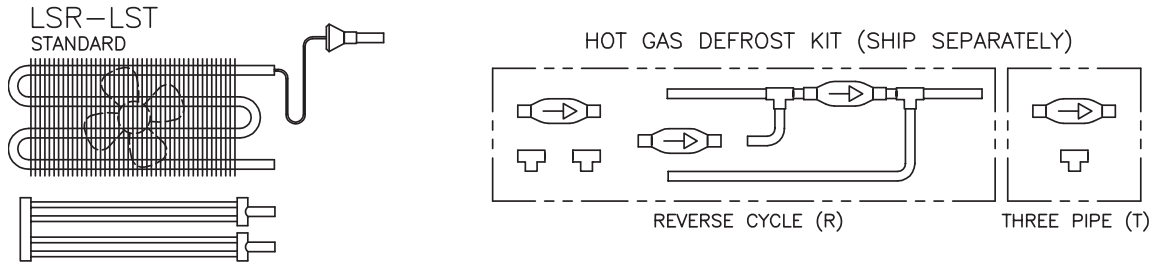

LSR/LST PIPING DIAGRAMS WITH OPTIONAL TXV MOUNTED

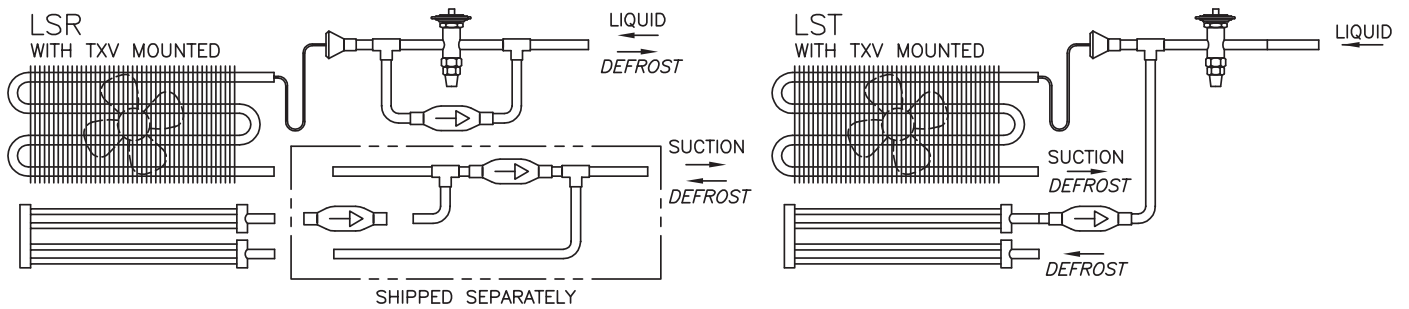

LPG/LPH/LAG/LAH STANDARD PIPING DIAGRAMS

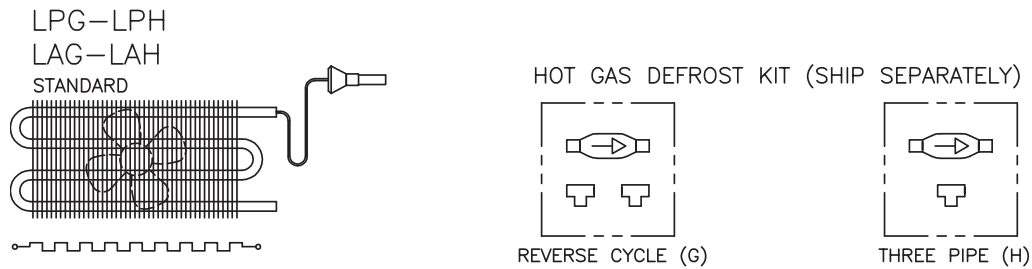

LPG/LAG PIPING DIAGRAMS WITH OPTIONAL TXV MOUNTED

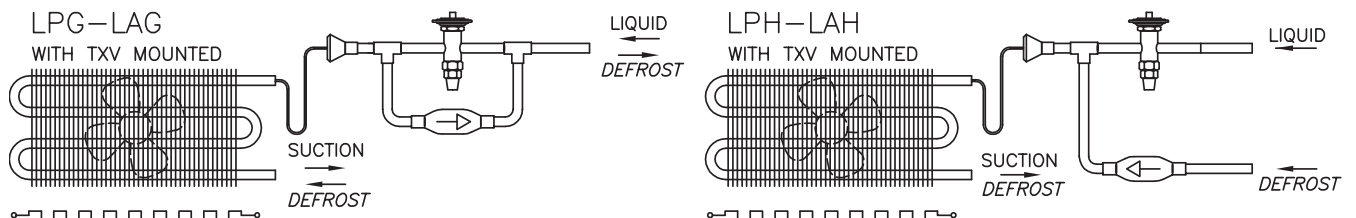

WIRING DIAGRAMS

Use copper conductor only

LSA, LPA & LAA

FIGURE 1

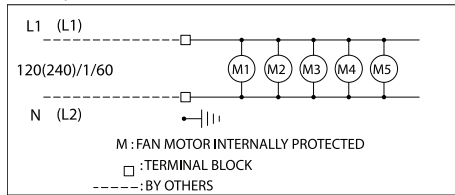

LSR & LST

FIGURE 2

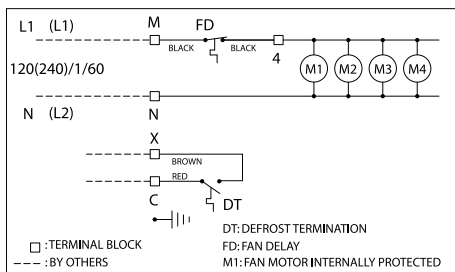

LSE, LPE & LAE

FIGURE 3

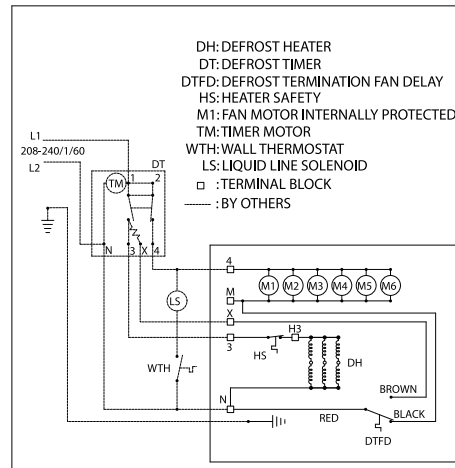

LPG, LAG, LPH & LAH

FIGURE 4

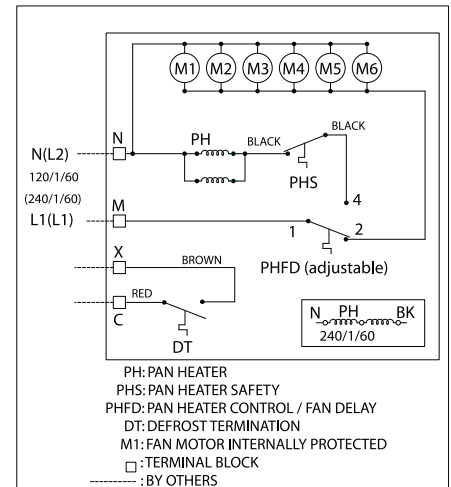

WIRING DIAGRAM FOR MULTIPLE ELECTRIC DEFROST UNITS

Use copper conductor only

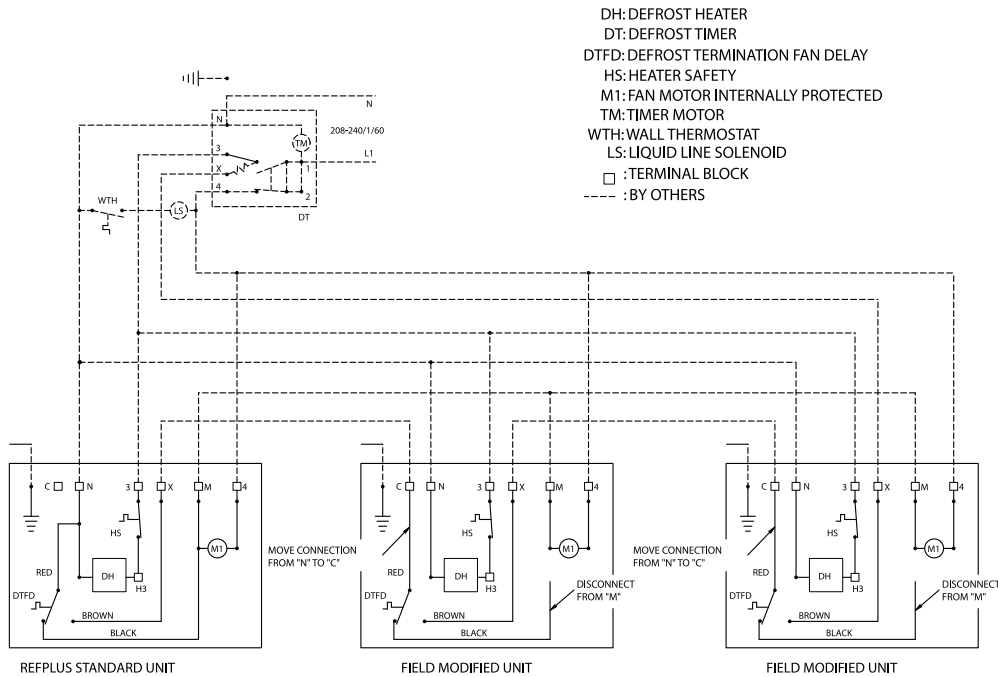

COMMERCIAL WALK-IN UNIT COOLERS AND FREEZERS

APPLICATIONS

- **LSA, LPA** and **LAA** Models are for coolers +34°F and above
- **LPE, LAE, LPG, LAG, LPH,** and **LAH** Models are for coolers +26°F and above
- **LSE, LSR** and **LST** Models are for coolers and freezers ranging from -20°F to +34°F

SPECIFICATIONS

High velocity **LS** Series are of a single coil construction for an air distribution directed towards the center of the cooler or the freezer. Fans draw air through the evaporator coil and discharge it through the fan guards on the front of the unit.

Medium velocity **LP** Series and low velocity **LA** Series are of a dual coil construction for an equal air distribution on both sides of the unit. The fans draw air upward through the fan guards and discharge it through each evaporator coil.

Coils are manufactured with seamless deoxidized heavy wall copper tubes and aluminum plate fins. For maximum heat transfer, tubes are mechanically expanded into self-spaced plate fins with full collar for a permanent bond. Connections and bends are brazed with a high temperature brazing alloy. Coils are factory leak tested at 400 psig and purged with -40°F dew point dry air. Coils are pressurized and sealed at 20 psig before assembly. Coils are circuited for HCFC and HFC refrigerants.

The casing material for **LS, LP** and **LA** Series is heavy-gauge textured aluminum. All units come with stainless steel or plated hardware for corrosion-free assembly. **LP** and **LA** Series are provided with triple drain pans to prevent condensation and sweating. The outside drain pan is hinged mounted and can be easily removed.

LS units are provided with a removable $\frac{7}{8}$ " I.D. copper drain fitting.

LP and **LA** series are provided with welded $\frac{3}{4}$ " FPT fitting.

Heavy-duty fan motors are provided for long life and dependable service. These motors are permanently lubricated, totally enclosed and thermally protected.

They are available for 120/1/60 or 208-240/1/60. Note: 208/240/1/60 volt motors can also be used for 200-230/1/50. Fan assemblies are statically and dynamically balanced for smooth and vibration-free operation.

Fan guards on **LS** series are injection-molded polymers for consistency of dimensions and full protection of moving parts. Fan guards are shaped

to improve air throw and to reduce noise level. Epoxy-coated welded wire guards are optional. Fan guards for **LP** and **LA** series are epoxy-coated welded wire.

All units are provided with large access panels. **LS** Series have front and side doors, **LP** and **LA** Series have a side access door.

LSE, LPE and **LAE** Models are provided with a sealed non-adjustable, fan delay / defrost termination thermostat, and a heater safety thermostat. All units feature incoloy low-watt density tubular heaters. They are imbedded within the coil for positive defrost and high-energy efficiency. This reduces heat gain in coolers and freezers. All units use six heaters for 208-240/1/60 or 208-240/3/60 supply. These units can be factory or field wired for either single or three-phase supply without reducing watt input and unbalancing the phases.

LSR and **LST** Models are provided with a sealed non-adjustable fan delay, defrost termination thermostat and a hot gas drain pan loop. An **LSR** Model can be used for reverse cycle defrost, or **LST** Model for three-pipe defrost.

LPG, LPH, LAG and **LAH** Models are provided with an adjustable fan delay thermostat and a non-adjustable defrost termination thermostat, heater safety thermostat, and electric drain pan heaters. **LPG** and **LAG** Models must be used for reverse cycle defrost, or **LPH** and **LAH** Models for three-pipe defrost.

All models are provided with terminal blocks for easier field wiring. Terminals are clearly identified to match wiring diagram supplied with the unit.

All *Commercial* Walk-In Unit Coolers are of modular design using a minimum number of parts to simplify replacement and to reduce inventory.

LS, LP and **LA** series can be easily modified at job site, to and from any defrost system.

© Copyright 2009 by RefPlus Inc.

RefPlus Inc. reserves the right to make any changes in the design or specifications of any product, at any time, without prior notice.

COM-06-09-RI-3K Printed in Canada.



USA & CANADA 1.888.816.2665

2777 Grande-Allée, St-Hubert, Quebec, Canada J4T 2R4
Tel.: (450) 641-2665 Fax: (450) 641-4554

www.refplus.com