

ICE RINK DEFOGGER® (PACKAGED)



IRD SERIES

5, 7.5 AND 10-TON MODELS

DEFOGGER®

MOISTURE REMOVAL RANGE
80°F (38°C) TO 30°F (-1.0°C)

APPLICATIONS

ARENAS

- SKATING
- HOCKEY
- CURLING



PATENTED

DESIGN FEATURES

- **AIR FLOW** separated from all refrigeration components, inhibits corrosion.
- **EASY ACCESS** for service. Servicing of unit can be done while unit is operating.
- **ENGINEERED** for **HIGH AIR FLOW** with design techniques to maintain optimal air flow through the dehumidification coil and maximize moisture removal.
- **COIL** fin material specially treated to facilitate draining of entrained moisture on evaporator.
- **TRUE SUB-COOLING** circuit to improve system efficiency.
- **SUCTION** line heat exchanger to protect the compressor from liquid slugging during the defrost cycle.
- **CONTINUOUS** fan operation to prevent humidity buildup on "off" cycle.
- **240 VOLT** control circuit.
- **EXTERNAL** high & low pressure service access valves and sight glass.
- **DEMAND** defrost system.
- **STAINLESS STEEL** heated drain pan with large 1 1/4" MPT drain connection.
- **INNOVATIVE** design for short defrost cycles providing more operational time.
- **HOT GAS** defrost: quick efficient defrost, minimizes compressor cycling.
- **FACTORY** assembled, wired, charged & tested.

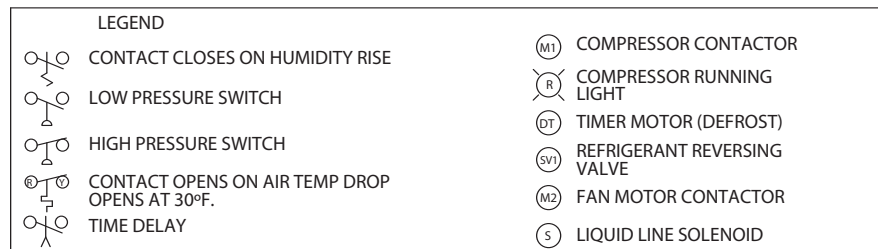
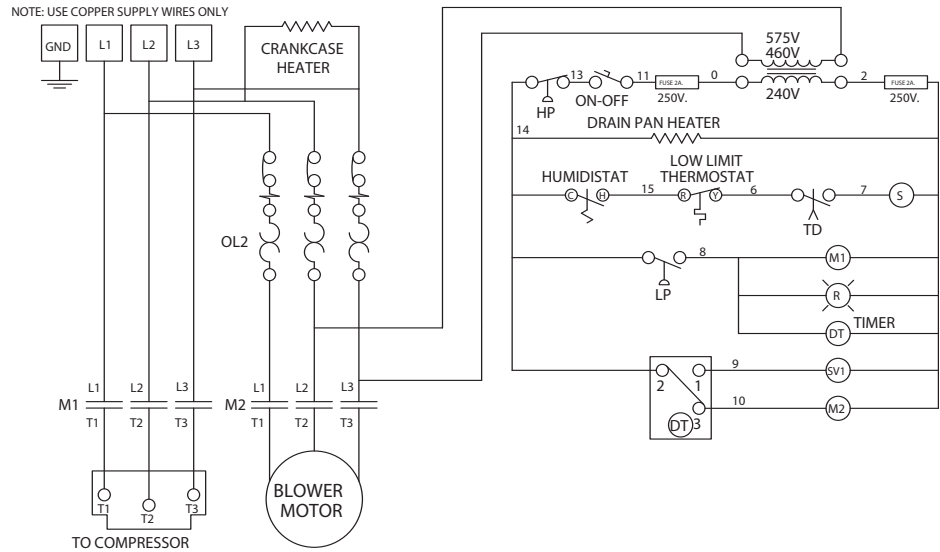

MODEL	RATED VOLTAGE	COMPRESSOR RLA	COMPRESSOR LRA	BLOWER MOTOR HP	BLOWER MOTOR FLA	DRAIN PAN HEATER WATTS	MIN. CIRC. AMPS	MAX. OVERCUR. PROT.	WIRE SIZE 60°C/100 FT
IRD-050-4R	208-240/1/60	34.3	165	2	12.5	195-255	56.5	90A	#4
IRD-050-5R	208-240/3/60	21.4	130	2	6.4	195-255	34.3	50A	#8
IRD-050-7R	480/3/60	10.0	71	2	3.2	255	16.3	25A	#12
IRD-050-8R	600/3/60	7.9	52	2	2.5	255	13.9	20A	#14
IRD-075-5R	208-230/3/60	30.1	183	3	9.0	195-255	48.2	75A	#6
IRD-075-7R	480/3/60	15.8	96	3	4.5	255	25.3	40A	#10
IRD-075-8R	600/3/60	12.4	79	3	3.6	255	20.4	30A	#10
IRD-100-5R	208-230/3/60	42.2	251	5	13.6	195-255	67	100A	#4
IRD-100-7R	480/3/60	18.4	117	5	6.8	255	30	45A	#8
IRD-100-8R	600/3/60	14.8	94	5	5.4	255	24	35A	#10

PERFORMANCE CHARACTERISTICS

MOISTURE REMOVAL IN LB./HR

MODEL	ENTERING AIR °F DB	RELATIVE HUMIDITY					
		100	90	80	70	60	50
IRD-050R	80	58.1	49.6	39.9	30.3	20.5	10.9
	70	51.6	43.1	35.2	27.3	19.5	11.5
	60	48.3	39.3	30.9	22.4	14.0	5.6
	50	36.8	29.7	22.8	16.1	9.2	2.4
	40	28.3	22.8	17.7	12.3	6.8	1.6
IRD-075R	80	74.3	63.9	54.4	44.7	35.1	25.6
	70	65.5	56.7	48.6	40.6	32.5	24.3
	60	53.9	45.6	37.8	29.9	22.1	14.3
	50	45.4	38.3	31.6	24.9	18.2	11.6
	40	35.2	29.8	24.6	19.2	14.1	8.7
IRD-100R	80	90.0	78.0	69.0	59.0	50.0	40.0
	70	80.0	70.0	62.0	54.0	45.5	37.0
	60	60.0	52.0	45.0	37.0	30.0	23.0
	50	54.0	47.0	40.0	33.0	27.0	20.0
	40	42.0	37.0	31.0	26.0	21.0	15.0

ADDED HEAT IN MBH

MODEL	ENTERING AIR °F DB	RELATIVE HUMIDITY					
		100	90	80	70	60	50
IRD-050R	80	94.2	85.3	70.9	59.9	48.6	37.3
	70	86.1	75.6	65.1	54.6	44.1	33.6
	60	70.4	62.0	53.6	44.1	35.7	27.3
	50	55.6	51.5	41.0	34.7	27.3	20.0
	40	45.1	39.9	33.6	28.4	22.1	16.8
IRD-075R	80	117.6	105.5	93.7	82.7	70.6	58.8
	70	109.2	98.7	87.2	76.7	66.2	54.6
	60	86.1	76.7	67.2	58.8	49.4	39.9
	50	67.2	59.9	53.6	47.3	39.9	33.6
	40	55.6	49.4	43.1	37.8	31.5	25.2
IRD-100R	80	140.9	133.6	123.9	114.2	104.5	96.4
	70	130.7	124.9	115.2	105.8	97.9	89.5
	60	103.0	97.0	88.7	81.0	73.0	65.3
	50	80.4	75.7	70.7	65.2	58.9	54.9
	40	66.0	62.5	56.8	52.0	46.5	37.8

Note: IRD-150R (2-stage) also available. Please contact factory.

- 1. Direct the air flow along the boards, do not direct air over the surface.
- 2. Discharge duct equipped with horizontally and vertically adjustable louvers supplied by others.

- 3. Unit should be 15 to 25 feet above ice surface. (Y)
- 4. Unit should be at a minimum of 4 feet from nearest obstruction. (X)

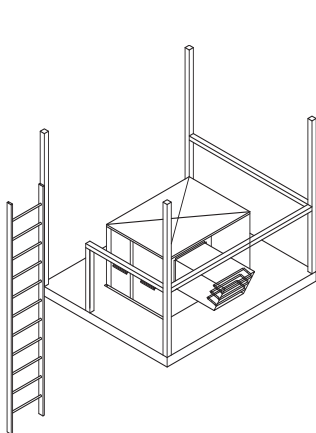

SUGGESTED PLATFORM

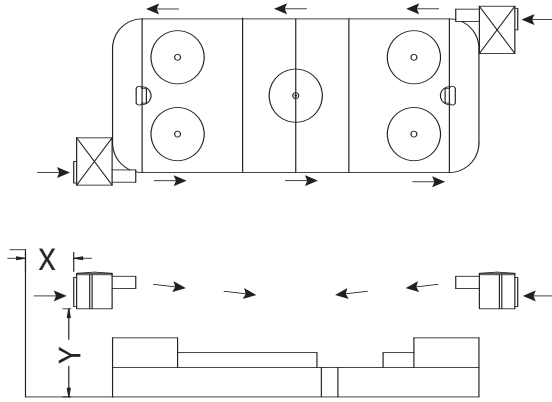

LOCATING THE DEFOGGER®

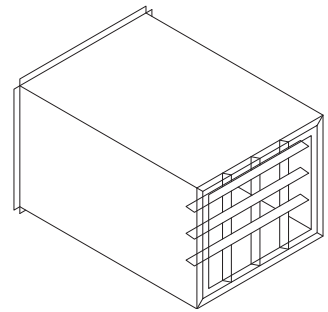

PROPOSED DIFFUSER

PIPING DIAGRAM

REFRIGERATION CYCLE

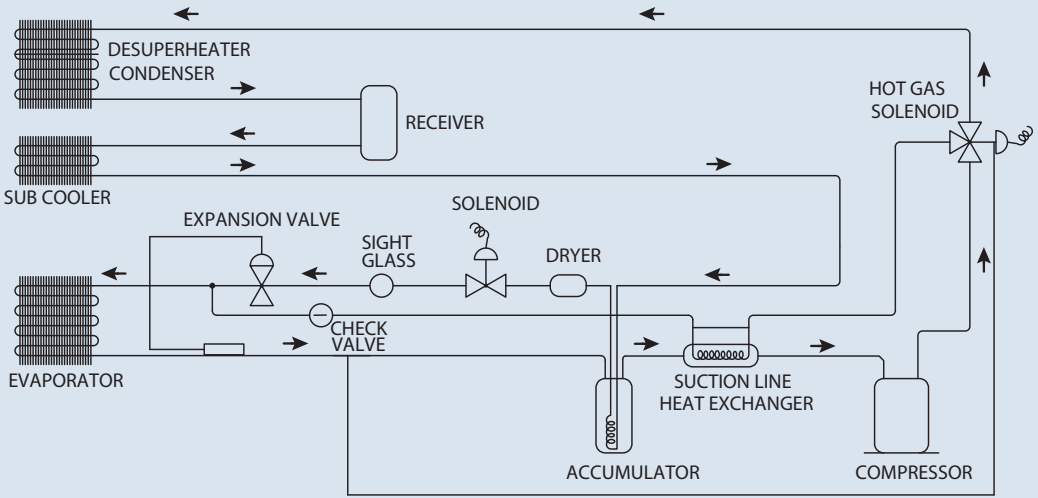

HOT GAS DEFROST CYCLE

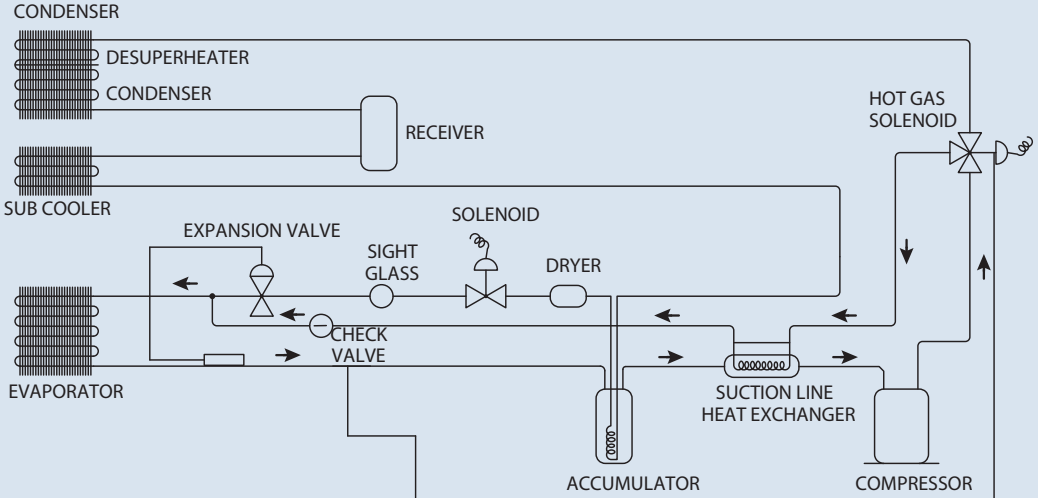

PHYSICAL DIMENSIONS

1. Humidistat
2. Running compressor light
3. Toggle switch for emergency
4. Power supply entry
5. High & low pressure taps
6. Access door for electrical & compressor
7. Access door for expansion valve
8. Liquid sight glass
9. Compressor removal access door
10. Mounting bolts for discharge diffuser
11. Blower motor & belt access door
12. Drain pan access door (Drain 1 1/4 MPT)
13. Air filter access door
14. Air intake & evaporator coil face

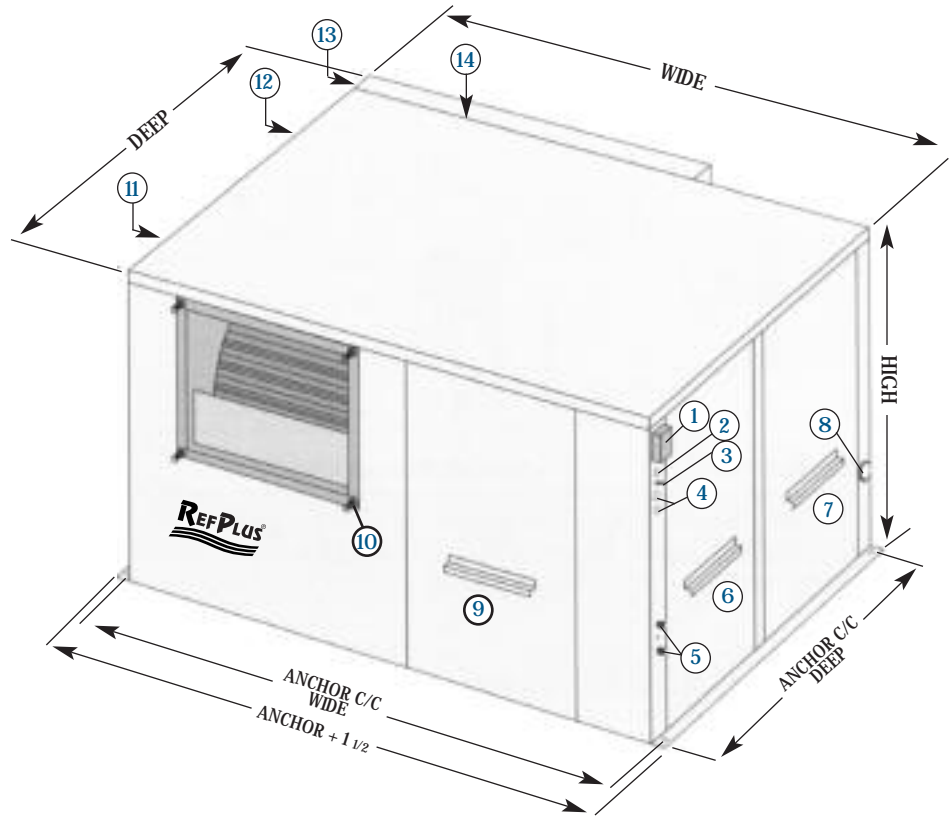

MODEL	OVERALL DIMENSIONS (INCHES)					BLOWER DISCHARGE (INCHES)		AIR VOLUME CFM	FILTERS	UNIT NET WEIGHT LB.
	WIDE	DEEP	HIGH	ANCHOR C/C		WIDE	HIGH			
IRD-050R	60	48	37.5	61.25	40.87	18.62	15.88	4500	2-16x20 2-20x20	820
IRD-075R	60	48	37.5	61.25	40.87	18.62	15.88	5500	2-16x20 2-16x20	895
IRD-100R	75.5	51.5	54.5	76.5	48.87	22.25	19.25	7500	6-16x25	1050

The contractor shall furnish and install where shown on the plan () RefPlus ICE RINK DEFOGGER® of the size indicated.

Installation shall include mounting platform and discharge diffuser. Each unit shall be factory assembled and include the following:

CASING shall be heavy gauge steel painted white with powder paint. Internal heated drain pan shall be constructed of stainless steel with 1 1/4 MPT connection.

UNIT shall be anchored to the platform with integral anchoring rails included in the casing.

AIR FLOW shall be separated from refrigeration components for easy servicing of unit while in operation.

COMPRESSOR shall be heavy duty, hermetic, suction cooled with internal motor protection, liquid slugging protection and centrifugal oil pump for long trouble-free operation. Compressor shall have internal suspension system and shall be installed with external rubber vibration absorber for vibration-free operation. Compressor shall be supplied with a crankcase heater to prevent refrigerant migration.

SUCTION ACCUMULATOR with boil out coil shall be included in each unit in the refrigerant path to ensure liquid-free refrigerant at the compressor. Also improves system efficiency by subcooling the liquid.

DEFROST HEAT EXCHANGER shall be included in each unit to eliminate flood back on defrost cycle.

RECEIVER shall be sized to hold the total refrigerant charge for easy service of the unit. Rotolock valves shall be supplied at inlet and outlet to isolate the refrigerant charge.

EXPANSION VALVE shall be balanced port type, specially engineered to operate efficiently at low head pressure thus reducing the power consumption at low ambient.

COILS (Evaporator, Condenser, Subcooler and Desuperheater) shall be constructed of die formed, collared, self-spacing aluminum plate fin and copper tube staggered in direction of air flow and mechanically bonded to give metal to metal contact for maximum heat transfer and patented desuperheating of the refrigerant circuitry. All coils shall be leak pressure tested after welding at 400 psig.

FILTERS shall be 2 inches, throw-away type, in an accessible filter rack with access door.

CENTRIFUGAL BLOWERS shall be forward curved statically and dynamically balanced, designed for efficient operation and shall have permanently lubricated ball bearings. Blowers shall operate constantly to maintain even humidity within the controlled area.

BLOWER MOTOR shall be open drip proof, ball bearing type, permanently lubricated. Overload relay shall be provided to protect all current phases.

PIPING shall be copper tube, brazed connections. Access fittings for high and low pressure shall be located outside the enclosure. Each system shall be evacuated, dehydrated and charged with operating charge of R-22. Each system shall be tested for performance and rating.

CONTROLS shall be located in an accessible, prewired, central control panel. Control panel shall include compressor contactor, blower motor starter, high and low pressure switch, time delay timer, defrost control and low ambient thermostat. Additionally, a humidistat shall be supplied and installed outside the control panel, on the exterior of the unit along with "Compressor running" indicator light and "On-Off" for emergency shutdown of the blower and compressor.

PUMP DOWN CYCLE All units to operate on a pump down cycle for a liquid free starting of the compressor and to minimize refrigerant migration.

DEFROST SYSTEM shall be of the Demand Defrost type, time actuated and temperature terminated. The hot gas defrost cycle shall be energized on fixed time intervals if ice is present on the evaporator and shall stop when the evaporator is ice free.

