



REFPLUS[®]



**DRY TYPE
FLUID COOLERS**





INTRODUCTION

The dramatic increase in city water and sewage rates, along with the costly operation of evaporative cooling towers, have created a demand for closed circuit cooling systems.

RefPlus offers a complete line of Dry Type Fluid Coolers for both commercial (air conditioning) and industrial (process cooling) applications. Our Dry Type Fluid Coolers can be designed to meet virtually any heat load – from as small as 10,000 Btu/hr to over 6 million Btu/hr.

RefPlus Dry Type Fluid Coolers are completely sealed, thereby requiring no make-up water or expensive chemical treatment. As these coolers are a closed circuit design, they conserve both water and energy, and are environmentally friendly. Most importantly, our systems are rated and sized specifically according to the customer's site and requirements.



NOMENCLATURE

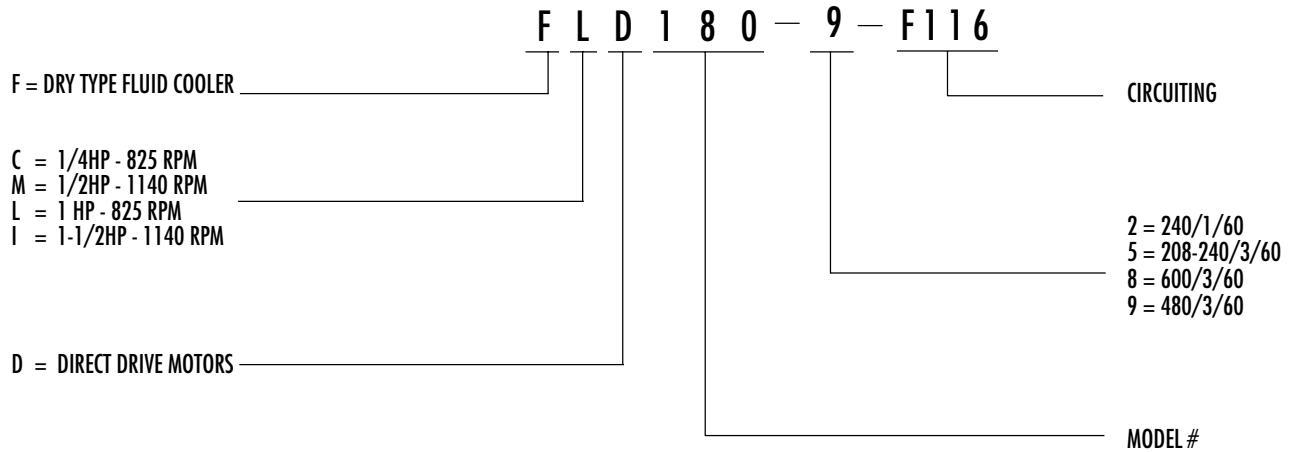

TABLE OF CONTENTS

TECHNICAL DATA	3
FCD/FMD DIMENSIONAL DRAWINGS	4
FLD/FID DIMENSIONAL DRAWINGS	5
CONTROL PANEL NOMENCLATURE & ELECTRICAL DATA	6
WIRING DIAGRAMS & DESIGN CRITERIA	7
UNIT SPECIFICATIONS	8

MODEL	AVAILABLE CIRCUITS							FAN ARR.	INTERNAL VOLUME (FT ³)		SHIP WEIGHT (LBS)	*DRAWING NUMBER
	"E" TYPE			"F" TYPE					"E" TYPE	"F" TYPE		
FCD02		-E2	-E3	-E4				1X1	0.15		190	CF110
FCD03		-E3	-E4	-E6				1X1	0.22		201	CF110
FCD04		-E4	-E6	-E8				1X1	0.30		210	CF110
FMD05		-E4	-E6	-E13				1X1	0.27		308	MF110
FMD07		-E7	-E14	-E21				1X1	0.41		335	MF110
FMD08		-E9	-E13	-E27				1X1	0.55		350	MF110
FMD09		-E4	-E6	-E13				1X2	0.52		489	MF120
FMD11		-E7	-E14	-E21				1X2	0.78		518	MF120
FMD12		-E7	-E14	-E21				1X2	0.78		532	MF120
FMD13		-E9	-E13	-E27				1X2	1.03		544	MF120
FMD14		-E9	-E13	-E27				1X2	1.03		566	MF120
FMD18		-E7	-E14	-E21				1X3	1.14		727	MF130
FMD20		-E7	-E14	-E21				1X3	1.14		741	MF130
FMD21		-E9	-E13	-E27				1X3	1.52		767	MF130
FMD23		-E9	-E13	-E27				1X3	1.52		789	MF130
FLD009	FID010	-E8	-E11	-E17	-F7	-F9	-F14	1X1	0.49	0.41	515	LF110
FLD010	FID011	-E8	-E11	-E17	-F7	-F9	-F14	1X1	0.49	0.41	525	LF110
FLD012	FID013	-E13	-E17	-E26	-F9	-F14	-F21	1X1	0.73	0.61	592	LF110
FLD013	FID014	-E13	-E17	-E26	-F9	-F14	-F21	1X1	0.73	0.61	602	LF110
FLD014	FID016	-E14	-E17	-E23	-F14	-F19	-F29	1X1	0.98	0.81	641	LF110
FLD015	FID017	-E14	-E17	-E23	-F14	-F19	-F29	1X1	0.98	0.81	654	LF110
FLD018	FID020	-E11	-E17	-E35	-F9	-F14	-F29	1X2	0.94	0.78	985	LF120
FLD021	FID023	-E11	-E17	-E35	-F9	-F14	-F29	1X2	0.94	0.78	1005	LF120
FLD023	FID025	-E13	-E17	-E26	-F9	-F14	-F21	1X2	1.41	1.17	1063	LF120
FLD026	FID029	-E13	-E17	-E26	-F9	-F14	-F21	1X2	1.41	1.17	1091	LF120
FLD028	FID031	-E17	-E23	-E35	-F14	-F19	-F29	1X2	1.88	1.56	1117	LF120
FLD030	FID034	-E17	-E23	-E35	-F14	-F19	-F29	1X2	1.88	1.56	1159	LF120
FLD035	FID039	-E17	-E26	-E52	-F14	-F21	-F43	1X3	2.08	1.73	1460	LF130
FLD040	FID044	-E17	-E26	-E52	-F14	-F21	-F43	1X3	2.08	1.73	1490	LF130
FLD042	FID046	-E22	-E34	-E70	-F18	-F28	-F58	2X2	1.88	1.56	1625	LF220
FLD043	FID049	-E23	-E35	-E70	-F19	-F29	-F58	1X3	2.78	2.30	1570	LF130
FLD045	FID051	-E23	-E35	-E70	-F19	-F29	-F58	1X3	2.78	2.30	1609	LF130
FLD049	FID054	-E26	-E34	-E52	-F18	-F28	-F42	2X2	2.82	2.33	1792	LF220
FLD050	FID055	-E17	-E26	-E52	-F14	-F21	-F43	1X4	2.76	2.28	1875	LF140
FLD053	FID058	-E26	-E34	-E52	-F18	-F28	-F42	2X2	2.82	2.33	1781	LF220
FLD054	FID059	-E17	-E26	-E52	-F14	-F21	-F43	1X4	2.76	2.28	1915	LF140
FLD056	FID064	-E34	-E46	-E70	-F28	-F38	-F58	2X2	3.76	3.11	1882	LF220
FLD057	FID065	-E23	-E35	-E70	-F19	-F29	-F58	1X4	3.68	3.05	2019	LF140
FLD060	FID068	-E34	-E46	-E70	-F28	-F38	-F58	2X2	3.76	3.11	1934	LF220
FLD061	FID069	-E23	-E35	-E70	-F19	-F29	-F58	1X4	3.68	3.05	2071	LF140
FLD063	FID070	-E22	-E34	-E70	-F18	-F28	-F58	2X3	2.78	2.30	2323	LF230
FLD066	FID073	-E17	-E26	-E52	-F14	-F21	-F43	1X5	3.43	2.84	2403	LF150
FLD070	FID079	-E23	-E35	-E70	-F19	-F29	-F58	1X5	4.58	3.79	2475	LF150
FLD075	FID085	-E23	-E35	-E70	-F19	-F29	-F58	1X5	4.58	3.79	2540	LF150
FLD080	FID088	-E34	-E52	-E104	-F28	-F42	-F86	2X3	4.17	3.45	2508	LF230
FLD085	FID095	-E46	-E70	-E140	-F38	-F58	-F116	2X3	5.55	4.60	2664	LF230
FLD090	FID101	-E46	-E70	-E140	-F38	-F58	-F116	2X3	5.55	4.60	2742	LF230
FLD099	FID112	-E34	-E52	-E104	-F28	-F42	-F86	2X4	5.52	4.57	3029	LF240
FLD106	FID119	-E34	-E52	-E104	-F28	-F42	-F86	2X4	5.52	4.57	3129	LF240
FLD113	FID129	-E46	-E70	-E140	-F38	-F58	-F116	2X4	7.35	6.09	3338	LF240
FLD120	FID137	-E46	-E70	-E140	-F38	-F58	-F116	2X4	7.35	6.09	3442	LF240
FLD124	FID141	-E34	-E52	-E104	-F28	-F42	-F86	2X5	6.86	5.69	4198	LF250
FLD132	FID149	-E34	-E52	-E104	-F28	-F42	-F86	2X5	6.86	5.69	4298	LF250
FLD142	FID162	-E46	-E70	-E140	-F38	-F58	-F116	2X5	9.15	7.58	4560	LF250
FLD150	FID171	-E46	-E70	-E140	-F38	-F58	-F116	2X5	9.15	7.58	4690	LF250
FLD159	FID178	-E34	-E52	-E104	-F28	-F42	-F86	2X6	8.21	6.81	5292	LF260
FLD170	FID194	-E46	-E70	-E140	-F38	-F58	-F116	2X6	10.95	9.07	5642	LF260
FLD180	FID205	-E46	-E70	-E140	-F38	-F58	-F116	2X6	10.95	9.07	5798	LF260
FLD190	FID214	-E58	-E86	-	-F48	-F72	-	2X6	13.69	11.34	6535	LF260

* REFER TO OUR ELECTRONIC CATALOG FOR PDF DRAWINGS



FCD DRY TYPE FLUID COOLER DIMENSIONS

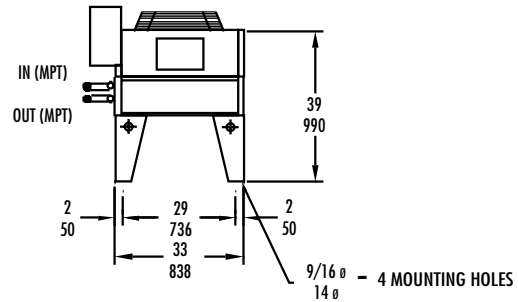
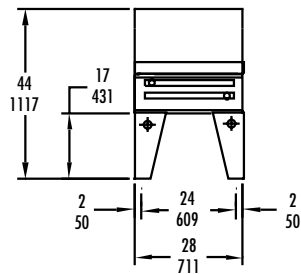

FMD DRY TYPE FLUID COOLER DIMENSIONS

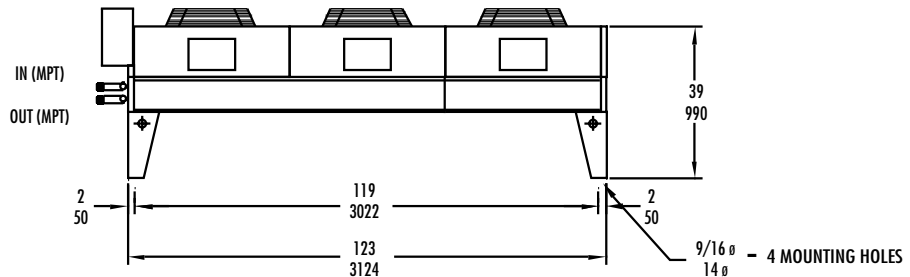
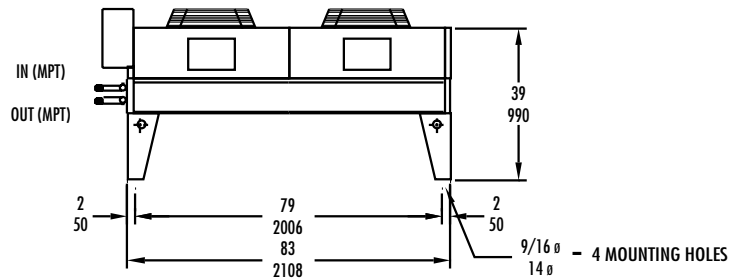
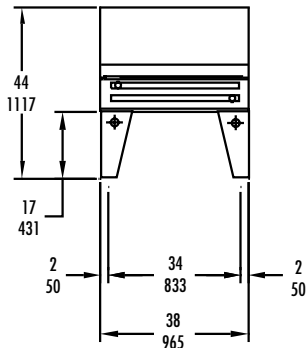
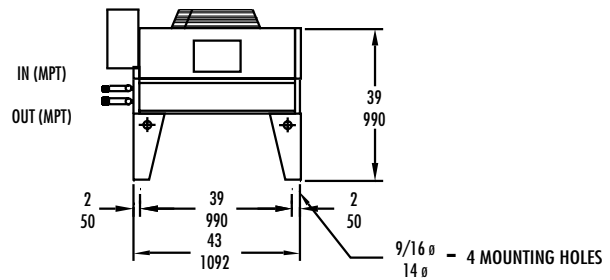

DIMENSIONS ARE IN INCHES
MM



FLD/FID DRY TYPE FLUID COOLER DIMENSIONS

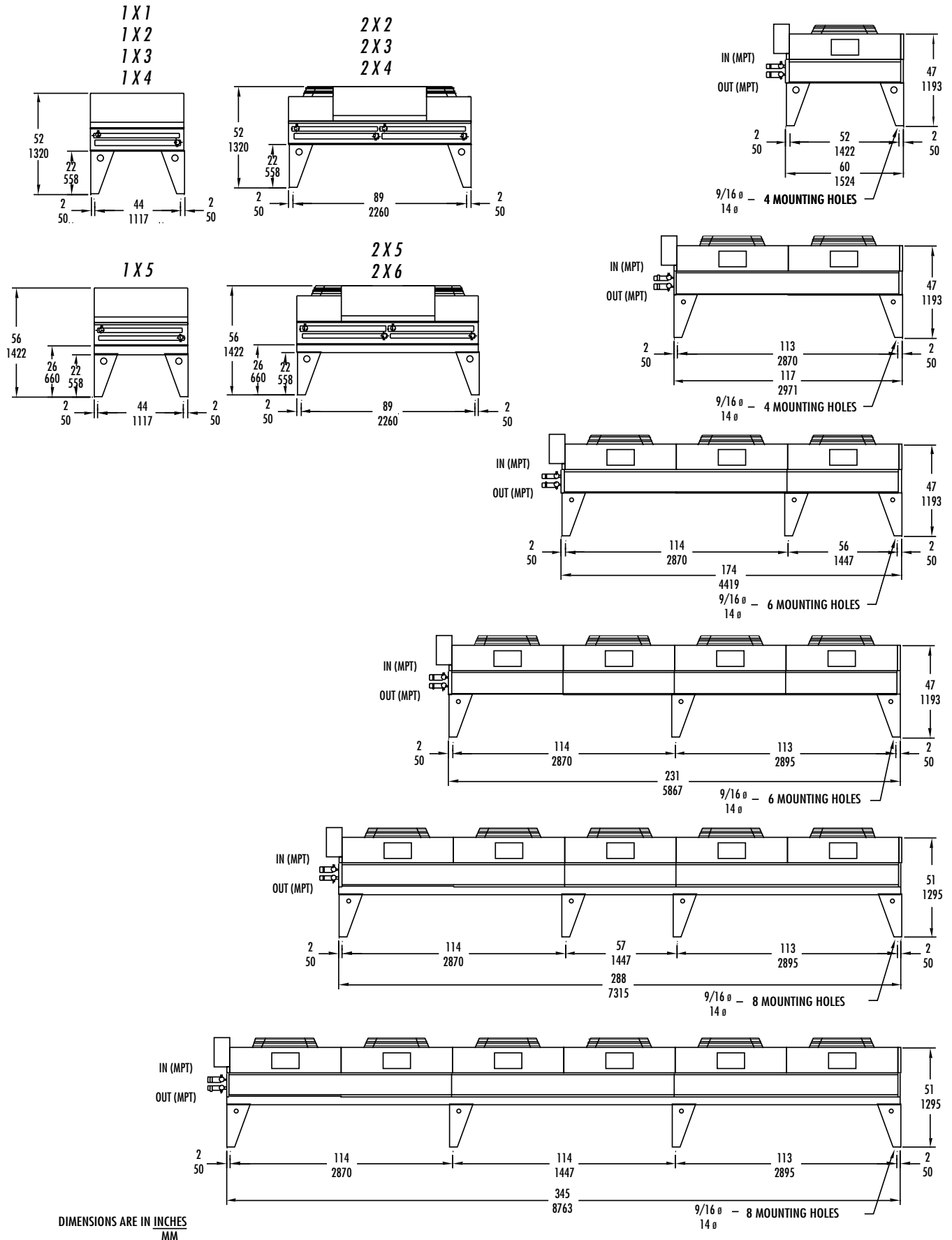

CONTROL PANEL NOMENCLATURE

REFPLUS PANEL	TYPE OF PANEL	FAN ARRANGEMENT	UNIT VOLTAGE	CONTROL VOLTAGE	OPTIONS
P	06	24	9	I	AE

<p>11 = 1 X 1 12 = 1 X 2 13 = 1 X 3 14 = 1 X 4 15 = 1 X 5 22 = 2 X 2 23 = 2 X 3 24 = 2 X 4 25 = 2 X 5 26 = 2 X 6</p>	<p>2 240/1/60 5 208-240/3/60 8 600/3/60 9 480/3/60</p>	<p>I 120V 2 240V X 24V N NONE</p>
---	---	--

N	NONE
A	MOTOR FUSING (IN PAIR FOR TWO FAN WIDE UNIT)
B	INDIVIDUAL MOTOR FUSING (FOR TWO FAN WIDE UNIT ONLY)
E	NON-FUSED DISCONNECT
F	FUSED DISCONNECT

STANDARD PANELS:

01	CONTROL BOX, TERMINAL BLOCK, NO CONTROLS, NO CONTACTORS
02	CONTACTOR(S) WITHOUT CONTROLS
06	CONTACTOR(S), ELECTRONIC AQUASTAT
07	CONTACTOR(S), ELECTRONIC AQUASTAT, FIRST STAGE CYCLING
10	CONTACTOR(S), MECHANICAL AQUASTAT
11	CONTACTOR(S), MECHANICAL AQUASTAT, FIRST STAGE CYCLING
12	CONTACTOR(S), MOTORS INDIVIDUALLY WIRED, NO CONTROLS
13	SPLIT ELECTRICAL, CONTACTOR(S), ELECTRONIC AQUASTAT
14	SPLIT ELECTRICAL, CONTACTOR(S), ELECTRONIC AQUASTAT, FIRST STAGE CYCLING
16	SPLIT ELECTRICAL, CONTACTOR(S), MECHANICAL AQUASTAT
17	SPLIT ELECTRICAL, CONTACTOR(S), MECHANICAL AQUASTAT, FIRST STAGE CYCLING

NOTE: PANEL AVAILABILITY DEPENDS ON MODEL CHOSEN. (PLEASE CONSULT FACTORY)

FAN MOTOR ELECTRICAL DATA

MODEL	QTY OF FANS	240/1/60		208-240/3/60		480/3/60		600/3/60	
		MCA	MOP	MCA	MOP	MCA	MOP	MCA	MOP
FCD									
02, 03, 04	1	2.1	15	N/A	N/A	N/A	N/A	N/A	N/A
FMD									
05, 07, 08	1	3.6	15	3.3	15	1.6	15	1.0	15
09, 11, 12, 13, 14	2	6.5	15	5.9	15	2.9	15	1.8	15
18, 20, 21, 23	3	9.4	15	8.5	15	4.2	15	2.6	15
FLD									
009, 010, 012, 013, 014, 015	1	N/A	N/A	5.5	15	2.5	15	2.0	15
018, 021, 023, 026, 028, 030	2	N/A	N/A	9.9	15	4.5	15	3.6	15
035, 040, 043, 045	3	N/A	N/A	14.3	15	6.5	15	5.2	15
042, 049, 053, 056, 060	4	N/A	N/A	18.7	20	8.5	15	6.8	15
050, 054, 057, 061	4	N/A	N/A	18.7	20	8.5	15	6.8	15
066, 070, 075	5	N/A	N/A	23.1	25	10.5	15	8.4	15
063, 080, 085, 090	6	N/A	N/A	27.5	30	12.5	15	10.0	15
099, 106, 113, 120	8	N/A	N/A	36.3	40	16.5	20	13.2	15
124, 132, 142, 150	10	N/A	N/A	45.1	50	20.5	20	16.4	20
159, 170, 180, 190	12	N/A	N/A	53.9	60	24.5	25	19.6	20
FID									
010, 011, 013, 014, 016, 017	1	N/A	N/A	7.5	15	3.8	15	2.9	15
020, 023, 025, 029, 031, 034	2	N/A	N/A	13.5	15	6.8	15	5.2	15
039, 044, 049, 051	3	N/A	N/A	19.5	25	9.8	15	7.5	15
046, 054, 058, 064, 068	4	N/A	N/A	25.5	30	12.8	15	9.8	15
055, 059, 065, 069	4	N/A	N/A	25.5	30	12.8	15	9.8	15
073, 079, 085	5	N/A	N/A	31.5	35	15.8	20	12.1	15
070, 088, 095, 101	6	N/A	N/A	37.5	40	18.8	20	14.4	15
112, 119, 129, 137	8	N/A	N/A	49.5	50	24.8	25	19.0	20
141, 149, 162, 171	10	N/A	N/A	61.5	70	30.8	35	23.6	25
178, 194, 205, 214	12	N/A	N/A	73.5	80	36.8	40	28.2	30

WIRING DIAGRAM

MULTIPLE CONTACTORS WITHOUT CONTROLS

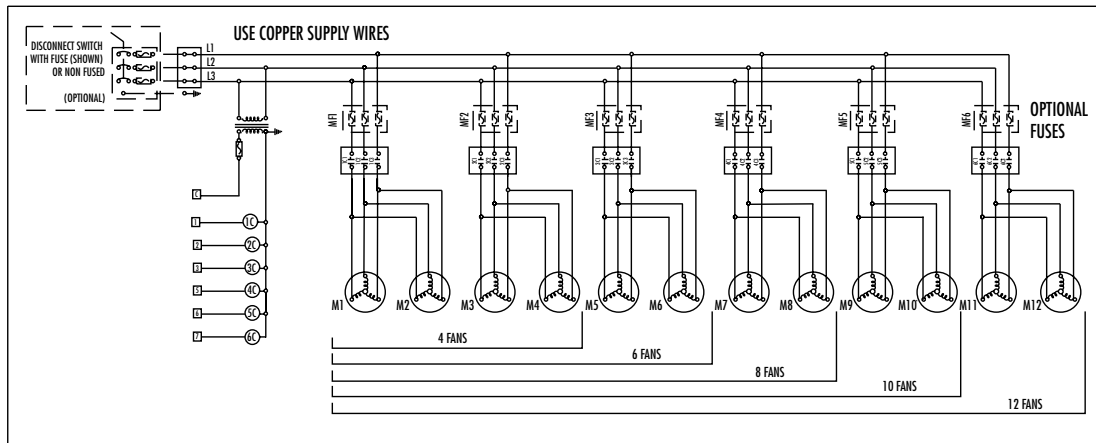

MULTIPLE CONTACTORS WITH CONTROLS

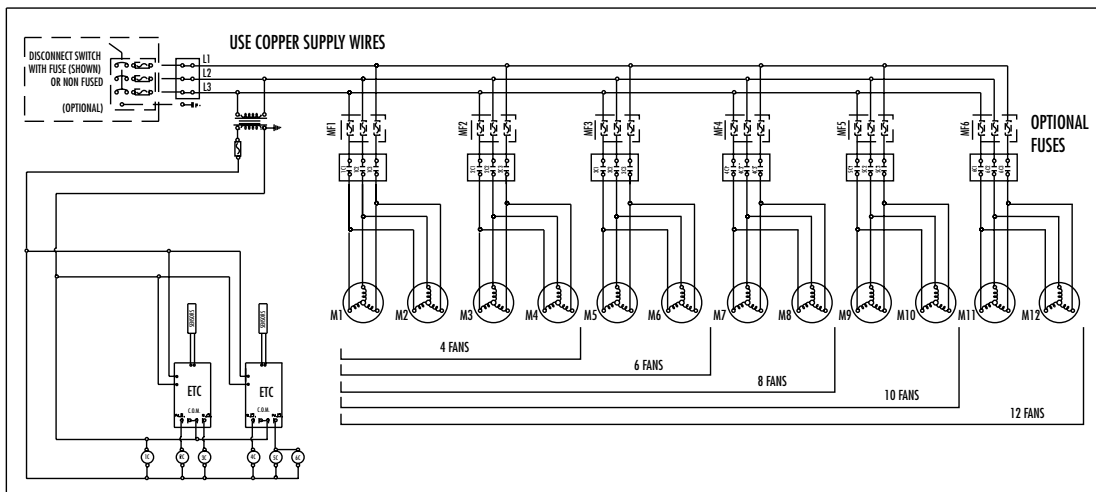

DESIGN CRITERIA

DESIGN CAPACITY = GPM x (Entering Fluid Temperature - Leaving Fluid Temperature) x Fluid Constant (Table 1)

Flow Rate (GPM)
 or Capacity (MBH): _____
 Ambient Temp.: _____
 Entering Fluid Temp.: _____
 Leaving Fluid Temp.: _____
 Max. Pressure Drop: _____ (if critical)

Fluid Type:

Water _____
 Ethylene Glycol _____ % concentration
 Propylene Glycol _____ % concentration

Table 1		Connection Sizes	
%	FLUID CONSTANT	GPM RANGE	SIZE (DIA.)
0	500	1-10	1-1/4
10	493	11-20	1-1/2
20	484	21-40	2
30	470	41-80	2-1/2
40	453	81-150	3
50	435	151-250	4
		250 & UP	SPECIAL

NOTE: Refer to RefPlus Dry Type Fluid Cooler Selection Software



SPECIFICATIONS:

Coils are manufactured using seamless, deoxidized, heavy wall, smooth copper tubes. They are mechanically expanded in self-spaced, full-collared aluminum corrugated plate fins for permanent bond and maximum heat transfer. Connections and bends are brazed with high temperature brazing alloy. The coil is factory leak-tested at 400 psig. All tube sheets are provided with oversized holes and tubes are supported in sliding tracks for friction-free assembly and maximum reliability.

Headers are made with seamless copper tubes and connections are made with pipe-threaded seamless red brass pipe. Headers include 1/2" NPT drain and vent.



Casings for all Fluid Coolers are heavy-gauge galvanized steel G90 with plated hardware for corrosion-free assembly. The cabinet is sectionalized with individual fan chambers. The unit is a bolted construction. Coil is independent of fan section. **FCD/FMD** models are provided with 1" punched venturies. All **FLD/FID** models are provided with 3-3/4" high-spun venturies for minimum noise and maximum efficiency. All models include side access panels for easy coil inspection and cleaning.

Fan Guards and Motor Mounts are welded wire construction for full protection from moving parts. Baked on powder epoxy coating provides corrosion protection.

Fans are aluminum blades riveted to a steel hub. They are statically and dynamically balanced for smooth and vibration-free operation. **FCD/FMD** fans are 20" in diameter with 4 blades. **FLD** fans are 30" in diameter with 4 blades and **FID** fans are 30" in diameter with 5 blades.

Fan Motors feature permanently lubricated, sealed ball bearings and inherent thermal protection for long life and dependable service.

Optional Control Panel can come complete with motor contactors and fuses (per motor or per pair of motors), two to four stage aquastat, terminal block and control transformer. Primary voltage is (208-240V, 480V, 600V) and secondary voltage is (24V, 120V & 240V).



All motors are wired to weather resistance box. The unit is provided with terminal blocks for easy field installation. Terminals are clearly identified to match wiring diagram supplied with the unit. Motors are wired using flexible cord type SOW 90°C (194°F) #16 AWG and they are terminated with liquid tight straight-through fittings.

FC-0301-REV-0R1-2K



1385, De Coulomb, Boucherville (Qc) Canada J4B 7L8
Tel.: (450) 641-2665 • Fax: (450) 641-4554 • Toll Free: 1-888-816-2665
Internet: www.dectron.com

